



**STANDARD SPECIFICATIONS FOR
PUBLIC WORKS CONSTRUCTION**

March 2026

TABLE OF CONTENTS

CITY OF FITCHBURG STANDARD SPECIFICATIONS FOR PUBLIC WORKS CONSTRUCTION

PAGE

	PAGE
SECTION 1 - GENERAL REQUIREMENTS	
1.1 DEFINITIONS AND TERMS	2001-1
1.2 GENERAL REQUIREMENTS	2001-2
SECTION 2 – EROSION CONTROL	
2.1 GENERAL	2002-1
2.2 MATERIALS	2002-1
2.3 EXECUTION	2002-2
SECTION 3 – EARTHWORK AND RESTORATION	
3.1 GENERAL	2003-1
3.2 MATERIALS	2003-2
3.3 EXECUTION	2003-5
SECTION 4 – CONCRETE AND CONCRETE STRUCTURES	
4.1 GENERAL	2004-1
4.2 MATERIALS	2004-1
4.3 EXECUTION	2004-2
4.4 FIELD QUALITY CONTROL AND TESTING	2004-6
SECTION 5 – PAVEMENTS AND BASE COURSE	
5.1 GENERAL	2005-1
5.2 MATERIALS	2005-1
5.3 EXECUTION	2005-5
5.4 FIELD QUALITY CONTROL AND TESTING	2005-9
SECTION 6 - STORM SEWER	
6.1 GENERAL	2006-1
6.2 MATERIALS	2006-1
6.3 EXECUTION	2006-3
6.4 FIELD QUALITY CONTROL AND TESTING	2006-6
SECTION 7 - WATER MAINS, HYDRANTS, AND SERVICE LATERALS	
7.1 GENERAL	2007-1
7.2 MATERIALS	2007-1
7.3 EXECUTION	2007-5
7.4 FIELD QUALITY CONTROL AND TESTING	2007-9
SECTION 8 - SANITARY SEWER MAINS AND LATERALS	
8.1 GENERAL	2008-1
8.2 MATERIALS	2008-1
8.3 EXECUTION	2008-3
8.4 FIELD QUALITY CONTROL AND TESTING	2008-7

SECTION 9 – STREET LIGHTING, TRAFFIC SIGNALS, AND SIGNAGE

9.1	GENERAL	2009-1
9.2	MATERIALS	2009-1
9.3	EXECUTION	2009-5

SECTION 10 - STANDARD DETAIL DRAWINGS (S.D.D.)

DESCRIPTION	S.D.D. NUMBER
--------------------	----------------------

EROSION CONTROL

FRAMED INLET PROTECTION	S.D.D. 2.01
-------------------------------	-------------

EARTHWORK AND RESTORATION

BOULDER RETAINING WALL DETAIL	S.D.D. 3.01
-------------------------------------	-------------

CONCRETE AND CONCRETE STRUCTURES

CONCRETE CURB AND GUTTER	S.D.D. 4.01
SIDEWALK & RAMPS	S.D.D. 4.02
COMMERCIAL DRIVEWAY	S.D.D. 4.03
RESIDENTIAL URBAN DRIVEWAY	S.D.D. 4.04
PATHS	S.D.D. 4.05

PAVEMENTS

STREET TYPES	S.D.D. 5.01
CUL-DE-SAC TYPES	S.D.D. 5.02
RESIDENTIAL RURAL DRIVEWAY	S.D.D. 5.03
SPEED TABLE	S.D.D. 5.04
TYPICAL SHOULDER	S.D.D. 5.05

STORM SEWER

STORM SEWER TYPICAL TRENCH	S.D.D. 6.01
CURB BOX	S.D.D. 6.02
INLET COVERS, TYPE H	S.D.D. 6.03
INLET FALSE WALL	S.D.D. 6.04
RCP ENDEWALL CONNECTION TO HDPE PIPE	S.D.D. 6.05
RIP RAP AND ENDWALL INSTALLATION	S.D.D. 6.06
CLASS III REINFORCED CONCRETE INLET	S.D.D. 6.07
POND IDENTIFICATION SIGN	S.D.D. 6.08
CUTOFF WALL DETAIL	S.D.D. 6.09

SANITARY SEWER AND WATER MAIN

SANITARY SEWER & WATER MAIN TRENCH	S.D.D. 7.01
FIRE HYDRANT	S.D.D. 7.02
WATER PRESSURE & LEAKAGE TEST	S.D.D. 7.03
SANITARY PRESSURE TEST CHART	S.D.D. 8.01

STREET LIGHTING, TRAFFIC SIGNALS, AND SIGNAGE

TREE PLANTING DIAGRAM	S.D.D. 9.01
PLANTING TECHNIQUE FOR TREES IN GRATES	S.D.D. 9.02
LB-3 LIGHT POLE BASE	S.D.D. 9.03
STREET SIGN INSTALLATION	S.D.D. 9.04
CROSSWALK AND STOP BAR	S.D.D. 9.05

SECTION 1 - GENERAL REQUIREMENTS

1.1 DEFINITIONS AND TERMS

City. The City of Fitchburg, Wisconsin.

City Contract. The written agreement between the City and the Contractor setting forth the obligation of the parties thereunder, including, but not limited to; the performance of the work to be done, the furnishing of labor and materials, the basis of payment, and contract time. Other contract documents are incorporated into the Agreement.

Contractor. The individual or entity with whom the Owner has entered into the Agreement.

Department. The City of Fitchburg Public Works Department.

Developer. The individual, partnership, joint venture, corporation or agency undertaking public improvements under the terms of the Sub-divider's Agreement and acting directly or through a duly authorized representative.

Sub-divider's Agreement. The agreement between the City of Fitchburg and the Developer setting forth the obligation of the parties thereunder for public improvements.

Sub-divider's Engineer. The consulting Engineer retained by the Developer and acting as the Sub-divider's representative.

Engineer. The City Engineer of the City of Fitchburg acting personally or through a duly authorized representative.

Inspector. A representative of the Engineer assigned and authorized to make detailed inspection of any and all portions of the work or materials.

Materials. Any substance specified for use in the construction of the project and its appurtenances.

Owner. A party who awards a contract for a project and undertakes to pay the contractor.

Plans. The approved plans, profiles, typical cross sections, and other drawings identified in the contract documents, which show the location, character, dimensions, and details of the work to be done.

Project. The total construction of which the Work to be performed under the Contract Documents may be the whole, or a part.

Project Area. The location of the construction to be performed under the contract.

Shop Drawings. All drawings, diagrams, illustrations, schedules, and other data or information which are specifically prepared or assembled by or for Contractor and submitted by Contractor to illustrate some portion of the Work.

Special Provisions. Special directions, provisions, or requirements peculiar to the project under consideration and not otherwise detailed or set forth in the Standard Specifications.

Specifications. The directions, provisions, and requirements contained and referenced herein, together with written agreements and documents incorporated in the contract documents, pertaining to the method or manner of performing the work, the quantities, and the quality of materials to be furnished under the contract.

Standard Specifications. The body of directions, provisions, and requirements contained herein, together with all supplements and addenda thereto.

Subcontractor. An individual or entity having a direct contract with Contractor or with any other Subcontractor for the performance of a part of the Work at the Site.

Supplemental Specifications. Specification adopted subsequent to the publication of these specifications.

Undistributed Quantity. A certain estimated amount of an item of work where the location is not yet determined. The work could take place anywhere within the City of Fitchburg municipal boundary.

Work. The entire construction or the various separately identifiable parts thereof required to be provided under the Contract Documents. Work includes and is the result of performing or providing all labor, services, and documentation necessary to produce such construction, and furnishing, installing, and incorporating all materials and equipment into such construction, all as required by the Contract Documents.

1.2 **GENERAL REQUIREMENTS**

1.2.01 **RELATED DOCUMENTS**

Specifications shall consist of the *City of Fitchburg Standard Specifications for Public Works Construction* latest edition (hereinafter referred to as “Fitchburg Specifications”) and the State of Wisconsin Standard Specifications for Highway and Structure Construction latest edition (hereinafter referred to as “WisDOT Specifications”), except as modified herein. Where there is conflict between the Fitchburg Specifications and the WisDOT Specifications, the Fitchburg specifications shall govern.

Standard Specifications shall reference the *Standard Specifications for Sewer and Water Construction in Wisconsin, latest edition*, (hereinafter “WUCA Specifications”) except as modified herein. Where there is a conflict between Fitchburg Specifications and the WUCA Specifications, Fitchburg Specifications shall govern.

1.2.02 **PRE-CONSTRUCTION CONFERENCE**

A pre-construction conference for the representatives of the Contractor and the City shall be held before the Contractor proceeds with the construction. The conference shall be arranged by the Contractor and shall be held at Fitchburg City Hall to discuss the project schedule and potential concerns of the City residents.

1.2.03 **OSHA**

All equipment, materials and work shall be in full accordance with the provisions of the “Occupational Safety and Health Act.” Any specification or requirement herein is in addition to OSHA requirements. If any specification or requirement conflicts with OSHA requirements, the OSHA requirement shall supersede.

1.2.04 **PERMITS**

The Contractor shall be responsible for obtaining all necessary permits needed for construction. These permits may include, but shall not be limited to: Street Opening Permit, Street Occupancy Permit, Erosion Control and Storm Water Management Permit (ECSWM), Driveway Permit, Bulk Water Use Permit, and Flushing Permit. These permits may be obtained on the 3rd floor at Fitchburg City Hall, from the Public Works Department. The work

associated with these permits shall be completed in accordance with all applicable statutes, ordinances, rules and regulations of the state and the City.

Submit copies of all other permits and approvals required for the project to the City prior to the start of construction.

State-issued blasting permits have additional notification requirements. For blasting permits, all adjacent parcels are required to be notified, regardless of distance from blasting location.

1.2.05 SHOP DRAWINGS

All drawings, diagrams, illustrations, schedules, and other data or information which are specifically prepared by or for the Contractor or Sub-divider's Engineer, or by subcontractor, manufacturer, fabricator, or supplier, which the Contractor is required to submit to the Engineer for approval.

1.2.06 PROTECTION OF PROPERTY IRONS AND MONUMENTS

Prior to commencing work, all existing property irons within the development shall be marked with steel fence posts. Steel fence posts shall extend five feet (5') above ground surface.

The Contractor shall be responsible for protecting and preserving all property irons and monuments during construction. At the completion of the project, the City will hire a Professional Land Surveyor (PLS) to reset all lost irons and monuments not replaced by the Contractor's PLS. The Engineer shall determine which irons and monuments were lost due to the Contractor's (or Contractor's subcontractor's) work, and shall, in addition to withhold up to \$1,000 for each lost or damaged iron and \$2,000 for each lost or damaged monument from the Contractor's payment as a deposit in addition to any other penalties under law. Once the actual costs of repair and/or replacement are determined, the actual costs shall be deducted from the Contractor's final payment. Under circumstances where the Contractor is performing work as part of a sub-divider's agreement, the actual costs shall be invoiced to the Owner.

All new property irons within the development shall be marked with steel fence posts. Steel fence posts shall extend five feet (5') above ground surface.

1.2.07 DRAWING SUBMISSIONS

One digital file of the record drawings by flash drive or electronic transfer shall be delivered to the Engineer within three (3) months of acceptance of the work. One set of 11" x 17" drainage drawings that show record elevations in enough detail to show drainage patterns match the design, to be submitted as a digital file by flash drive or electronic transfer. All coordinates shall be in the Dane County Coordinate System, NAD 1983 (2011) WISCRS Dane County US Survey Feet. All elevations shall be referenced to NAVD 88, Feet. Elevations based on the City of Madison, Lake Mendota Datum will not be accepted. The digital file of the record drawings shall be in AutoCAD format and shall include a plan layout of the entire project and plan and profile layouts utilizing the Dane County Coordinate System. All layers in the digital file shall have names consistent with the National CAD Standard. An AutoCAD template drawing is available from the Public Works Department. Along with the above submittals provide two points, at opposite corners of the project, in Dane County Coordinates and in Universal Transverse Mercator Coordinates of an existing, easily recognizable, and immobile object (fire hydrant, street light, etc.). In the event that accurate record drawings are not submitted in a timely fashion, the Engineer reserves the right to restrict commencement of subsequent project phases and/or assess the Developer for actual expenses incurred for creation of such drawings.

Contractor's construction notes, as well as televised sewer and survey information shall be incorporated into the record drawings. The Contractor shall maintain in a safe place one (1) copy of all drawings with construction notes, for the use of generating record drawings, which include the measurements listed below. Sewer lateral locations at the main, as indicated on the sewer televising report, shall be incorporated into the record drawings. All exposed utilities, property pins, and all visible changes made to City infrastructure during construction shall be re-surveyed. The re-surveyed record drawing information for all utilities shall include the location, elevations, and adjusted pipe slopes, if applicable, for all utility infrastructure. Applicable elevations include, but are not limited to, rim elevations, pipe invert elevations, and top hydrant nut elevations.

Contractor's construction notes shall include all changes made during construction, locations and depth of any abandonments, and the measurements listed below. Failure of Contractor to provide required construction notes shall result in a 5% deduction in contract price for the installation and materials of each utility construction notes are not provided for.

- A. Storm Sewer.** A complete and accurate tabulation of length and depths of all storm sewers shall be kept by Contractor. Depths of all storm sewer pipe inverts at each structure shall be recorded (distance between invert of each pipe and top of curb or rim if in the roadway).
- B. Water Main.** A complete and accurate tabulation of the length, depth and location of all water main fittings, laterals, corporations and curb stops shall be kept by Contractor. All buried utility fittings shall be tied to two permanent landmarks such as valves, manhole castings, property irons, etc. For water services the distance from main to curb stop and the curb stop to end of the service shall be recorded.
- C. Sanitary Sewer.** A complete and accurate tabulation of length, depth and location of all sewer branches, risers, laterals, and wyes shall be kept by Contractor. Measurement shall be made from the nearest downstream manhole, or equivalent permanent landmark.

The following information for each listed item shall be placed in a Dbase IV or ASCII table and provided to the City within three (3) months of acceptance. All coordinates shall be in the Dane County Coordinate System, NAD 83(1991), US Survey Feet. All elevations shall be referenced to NAVD 88, Feet. Elevations based on the City of Madison, Lake Mendota Datum will not be accepted.

Item	Dbase IV or ASCII Table Information
Sanitary Sewer Structures	Feature Number, Type of Feature, Year of Installation, Street, Easting, Northing, Rim Elevation, Invert Elevation
Sanitary Sewer Pipe	Feature Number, Type of Feature, Year of Installation, Street, Invert Elevation, Pipe Material, Pipe Size, Pipe Length, Slope, Up Stream Manhole
Sanitary Sewer Lateral	Feature Number, Type of Feature, Year of Installation, Street, Invert Elevation, Pipe Material, Pipe Size, Pipe Length, Slope, Up Stream Manhole, Distance from upstream manhole to lateral
Storm Manholes	Feature Number, Type of Feature, Year of Installation, Street, Easting, Northing, Rim Elevation, Invert Elevation
Storm Pipe	Feature Number, Type of Feature (box culvert, feeder, main, etc.), Year of Installation, Street, Invert Elevation, Pipe Material, Pipe Size, Pipe Length, Slope, Up Stream Manhole
Storm Outfalls	Feature Number, Type of Feature, Year of Installation, Street or nearest street, Easting, Northing, Invert Elevation, Size, Material, Endwall (Y/N), Grate (Y/N), Treatment (Riprap, Grass Swale, Gabion, etc.)
Storm Inlets	Feature Number, Type of Feature (H, Beehive, Field, Driveway, etc.) Year of Installation, Street, Easting, Northing, Rim Elevation, Invert Elevation

Water Valves	Feature Number, Type of Feature (Gate, Butterfly, Service, etc.) Year of Installation, Street, Easting, Northing, Rim Elevation, Cover (Valve Box, Manhole, Curb Stop), Purpose (Main, Service, Hydrant), Size, Material
Water Main Pipe	Feature Number, Type of Feature, Year of Installation, Street, Start and Ending x-y Coordinates, Pipe Material, Pipe Size, Pipe Length
Water Main Bends	Feature Number, Type of Feature, Year of Installation, Street, Easting, Northing, Invert Elevation, Pipe Material, Pipe Size, Pipe Length, Degree, Orientation (Horizontal or Vertical)
Fire Hydrants	Feature Number, Type of Feature, Year of Manufacture, Street, Easting, Northing, Top Nut Elevation, Address (if known)
Water Service Laterals	Feature Number, Type of Feature, Year of Installation, Street, Invert Elevation, Lateral Material, Lateral Size, Lateral Length (Main to Service Valve), Address (if known)
Benchmarks	Benchmark Number, Location of Benchmark, Type of Benchmark, Year of Benchmark, Elevation
Street Signs	MUTCD sign code, Label
Streetlights	Fixture Type, Pole Type, Arm, Transformer Base, P.C. Sensor, Lamp Type
Pavement Marking Lines	Material, Color, Width, Type
Pavement Marking Symbols	Material, Color, Type, Size
Pavement Marking Area	Material, Color, Type

1.2.08 PLANT VALUES SUBMISSIONS

A copy of the final construction costs, broken down per item, shall be submitted to the Engineer by December 15 of the year in which the construction is completed.

1.2.09 ACCEPTANCE OF IMPROVEMENTS

When the Contractor considers the entire work completed, the Contractor shall notify the Engineer in writing that the work is complete and request that the Engineer conduct an inspection of the work. Within a reasonable time thereafter, the Contractor and the Engineer shall make an inspection of the work to determine the status or completion. If the Engineer does not consider the work to be complete or satisfactory in any way, the Engineer will notify the Contractor in writing of the reasons. At that time, any defects or imperfections that appear in the whole or any part of the work, which are caused by or due to any fault or negligence of the Contractor, shall be corrected before the work is accepted. Upon completion of the work to repair the defects and/or imperfections of the Contractor, the Contractor shall notify the Engineer in writing that the work has been completed. If, upon inspection, the work is found to be satisfactory and complete by the Engineer, and the other requirements listed herein have been met, the project will be considered accepted. At the discretion of the Engineer, conditional acceptance may be granted prior to the completion of the asphaltic surface course.

Within three months of acceptance of public improvements subdivider shall submit documentation demonstrating that the as-built stormwater treatment facilities (e.g., ponds, infiltration basins, bioretention basins, etc.) meet the stormwater requirements as documented in the Stormwater Report.

No project shall be accepted prior to Contractor's submission of final lien waivers for Contractor and Contractor's subcontractors and proof of street light warranties.

No project shall be deemed complete until all excess mud, bituminous material, and other objectionable material are removed from the sidewalk, terrace, gutter, and pavement; inlets and storm sewers cleaned, and erosion control measures in place.

1.2.10 GUARANTEE OF WORK

Unless otherwise stated in the special provisions, the Contractor shall guarantee the work related to all public improvements for a minimum period of one (1) year from the date of final acceptance. For City let projects, the Contractor shall also guarantee any replacement or repair work, as required for any defective improvements for a minimum period of one (1) year from the date of final acceptance of the replacement or repair work.

1.2.11 TRAFFIC CONTROL

When the project work is on or adjacent to an active roadway, vehicular and pedestrian traffic shall be maintained at all times, unless specifically permitted by the Engineer. The Contractor shall notify the Fitchburg-Public Works Department (608-270-4260) a minimum of seven (7) business days in advance of any planned detours or other roadway work that may impede the movement of emergency vehicles. The Contractor shall be responsible for notifying residents who will be affected by the construction. Resident notifications shall include the following information at minimum:

- Company name
- Project contact name
- Project contact phone number
- Date and time of start and end of traffic disruption
- The words "Please contact (provide contact person and contact information) if additional considerations are needed because of a disability."

The Contractor shall provide a copy of the notification for review by the City prior to resident notification. The Contractor shall provide written notice to the City of each address that has been notified, along with the date and method of notification, at least 72-hours before the traffic disruption begins.

All work shall be in conformance with the latest edition of the Manual of Uniform Traffic Control Devices (MUTCD) and the appropriate supplements for its use in the State of Wisconsin, and these specifications. This manual is available at <http://mutcd.fhwa.dot.gov/>.

All traffic control barricades shall be weighted down with sand bags or other approved methods. \$200 per day shall be deducted from Contractor's total contract price for traffic control that is not maintained per MUTCD requirements.

Contractor is responsible for maintaining visible stop signs during all construction phases.

Contractor shall install temporary no parking signs and submit photos of all installed signs to Engineer a minimum of 48 hours prior to parking restrictions. Contractor shall label temporary no parking signs for only the duration parking needs to be restricted to accommodate the work. Contractor shall remove temporary no parking signs within 48 hours of restriction. No parking signs shall be obtained from the City.

1.2.12 STREET CLOSING NOTIFICATONS

All Contractors performing work on City contracts or as a part of a Sub-divider's agreement shall give the Engineer notice of their intent to begin work on any City street a minimum of 48 hours in advance of commencing operations. If it is deemed necessary by the Contractor that a detour be used during the duration of the project, the Engineer shall be given at least seven (7) business day notice. Saturdays, Sundays, and legal holidays shall not be included in the measurement of notice time. Further notice shall be given of any major change in project scheduling following the original notification. The Contractor shall provide a timeline for all closures and give emergency services five (5) day notice of actual closure.

The Contractor shall not in any manner unnecessarily obstruct the streets or crossing, and shall, under all circumstances, provide safe and sufficient means of travel for pedestrians and vehicles.

The Contractor shall not, at any time, close any street to the public except by express permission of the Engineer.

1.2.13 TESTING AND SAMPLING

All materials shall be subject to testing, and shall be tested if so ordered by the Engineer. The Contractor shall furnish without charge all samples and such facilities necessary for the collection and forwarding of such samples. Unless otherwise specified elsewhere herein, all testing shall be completed by the City's subcontractor. When applicable, the contractor shall use the City's standard testing forms.

1.2.14 MATERIALS

All materials used in construction shall be new materials (i.e. manufactured within the last 18 months) unless otherwise approved by the Engineer. Any discoloration, corrosion, cracking, fading, or any other defect is unacceptable. The Contractor is responsible for ensuring all materials on site meet City Standards.

1.2.15 CONSTRUCTION STAKING

Global Position System (GPS) is not allowed for staking elevations of municipal sanitary sewer, storm sewer, water main, sidewalk, and curb and gutter, unless authorized by the Engineer. Contractor is required to provide field verification of any horizontal and vertical staking completed with GPS equipment. Verification shall consist of tying staking survey to two known control points and establishing accurate horizontal and vertical positioning. For curb and gutter installation, staking is required at minimum fifty-foot intervals, at all vertical and horizontal transitions, at all curb openings, and at all inlets. Two stakes are required at each inlet to verify position and height.

1.2.16 TREE PROTECTION

These specifications shall be applicable to all Contractors working in the Public Right of Way, whether by permit, Public Works Contract, Sub-divider's Agreement or any other permission to work within the Public Right of Way. For the purposes of these specifications, "Public Right of Way" shall include any property that the City of Fitchburg has an ownership interest in, including, without limitation, highways and highway right-of-ways, public walkways and bike paths, parks, greenways and stormwater management areas.

Damage can be prevented or minimized by following the specifications below and properly educating construction staff of these specifications and use of care when working around trees during the construction process. If the City determines that a tree has been damaged due to

failure to follow these specifications, or negligence of the Contractor or Subcontractor, a fine or liquidated damages shall be assessed to the Contractor or permit holder.

The Contractor shall not grade, excavate, or otherwise disturb the area within ten feet (10') of any tree as measured from the outside edge of the tree trunk or visible aboveground portion of the root system.

All roots over one (1) inch in diameter that are damaged shall be cleanly cut immediately in back of the damaged section on the same day of the excavation. Cuts may be made with lopping shears, chainsaw, stump grinder, or other means which will produce a clean cut. Exposed roots should be covered as soon as excavation and installation are complete. The Contractor shall not rip or pull roots out towards the trunk of a tree while excavating with a backhoe. The use of a backhoe to cut roots is NOT acceptable.

Contractor shall take precautions during construction not to disfigure, scar, or impair the health of any tree on public or private property. All pruning shall be done according to ANSI A300 tree pruning specifications.

Contractor shall notify City Staff the same day of any damage to trees resulting from construction activities.

No equipment or materials will be allowed to be parked on, driven over, or be piled on areas within ten feet (10') of a tree as measured from the outside edge of the tree trunk or visible aboveground portion of the root system.

Where construction damage occurs or results in removal of the tree. The contractor is responsible for any repairs or replacement of the tree per the City Forester.

END

SECTION 2 - EROSION CONTROL

2.1 GENERAL

2.1.01 RELATED DOCUMENTS

Wisconsin DOT Erosion Control Product Acceptability List (PAL), latest edition available at <http://wisconsindot.gov/Pages/doing-bus/eng-consultants/cnslt-rsrces/tools/pal/default.aspx>

Dane County Erosion Control & Stormwater Management Manual available at <https://lwr.danecounty.gov/tools/ecsm-manual> and the *Wisconsin DNR Technical Standards* available at http://dnr.wi.gov/topic/stormwater/standards/const_standards.html

City of Fitchburg Erosion Control and Stormwater Management Permit Application information available at <https://www.fitchburgwi.gov/231/ECSWM-Requirements>

2.1.02 DESCRIPTION OF WORK

There are a variety of strategies for minimizing soil loss from construction sites. These include preventing soil detachment, diverting runoff around disturbed areas, and trapping sediment carried by runoff before it leaves the site. The most important strategy for controlling construction site erosion is preventing soil particle detachment through soil stabilization. Vegetation shall be reestablished as soon as possible after land is disturbed. In the meantime, other erosion control practices, such as polymer application, erosion matting, and mulching, must be in place. A second line of defense is to prevent runoff from contacting detached soil particles by diverting runoff around disturbed areas. Diversions minimize the opportunity for runoff to entrain detached soil particles and carry them offsite. Finally, when soil particles are detached and carried by runoff, practices that slow and/or trap sediment must be installed to prevent suspended sediment from leaving the site and entering water bodies.

2.2 MATERIALS

2.2.01 EROSION CONTROL MATERIALS

Erosion control materials shall conform to the WisDOT PAL or as specified in the Dane County Erosion Control and Stormwater Management Manual unless otherwise approved in writing by the Department.

2.2.02 INLET PROTECTION

Framed inlet protection shall meet ASTM Standard D8057-17 requirements including:

- a. Bypass overflow that meets or exceeds inlet design flow
- b. Frame and bags strong enough to handle full sediment load
- c. For combination inlets, capture runoff entering both grate and curb opening
- d. "Dual fabric" filter bag, with nonwoven bottom and woven top

Framed inlet grates shall be installed in all inlets unless approved otherwise by Engineer. Field inlets shall be protected as approved by Engineer. Once installed, no portion of the inlet protection (fabric bag) shall project above grate.

2.3 EXECUTION

2.3.01 EROSION CONTROL PERMIT REQUIRED ON SITE

Contractor shall maintain a copy of the approved Erosion Control and Stormwater Management Permit on-site at all times until final stabilization of the project is achieved.

2.3.02 EROSION CONTROL INSTALLATION, MONITORING, MAINTENANCE, & REMOVAL

The installation, monitoring, maintenance, and removal of erosion control shall conform to the Dane County Erosion Control and Stormwater Management Manual unless otherwise approved by the Department.

END

SECTION 3 - EARTHWORK AND RESTORATION

3.1 GENERAL

3.1.01 RELATED DOCUMENTS

WisDOT Specifications, latest revision available at <https://wisconsindot.gov/Pages/doing-bus/eng-consultants/cnslt-rsrces/rdwy/stnds-spec.aspx>

City of Fitchburg Tree Protection and Pruning Guidelines available at <https://www.fitchburgwi.gov/638/Tree-Owners-Guide>

3.1.02 DESCRIPTION OF WORK

Earthwork includes clearing and grubbing, excavation, fill, compaction, and grading of material to meet the subgrade elevations indicated and subsequent disposal of surplus materials from the project. Restoration includes the provision and placement of topsoil, seed, fertilizer, and mulch or erosion mat for the disturbed areas within the project.

3.1.03 SITE CONDITIONS

A. Existing Utilities. Locate existing underground utilities in areas of work. If utilities are to remain in place, provide adequate means of support and protection during earthwork operations.

Should uncharted, or incorrectly charted, piping or other utilities be encountered during excavation, consult utility owner immediately for directions. Cooperate with Owner and utility companies in keeping respective services and facilities in operation. Repair damaged utilities to satisfaction of utility owner.

B. Protection of Existing Trees and Vegetation. Protect existing trees and other vegetation indicated to remain in place, against unnecessary cutting, breaking or skinning of roots, skinning and bruising of bark, smothering of trees by stockpiling construction materials or excavated materials within drip line, excess foot or vehicular traffic, or parking of vehicles within drip line.

Where indicated on drawings, Contractor shall provide temporary measures to protect trees and vegetation to be left standing. Temporary measures shall be installed prior to the start of construction. All unidentified trees with drip lines in the construction zone shall be reported to the City prior to the commencement of construction activities. Contractor shall follow the City of Fitchburg Tree Protection and Pruning Guidelines, see Section 3.1.01 RELATED DOCUMENTS.

C. Protection of Persons and Property. Barricade open excavations occurring as part of this work and post warning lights. Operate warning lights as recommended by authorities having jurisdiction. Protect structures, utilities, sidewalks, pavements, and other facilities from damage caused by settlement, lateral movement, washout and other hazards created by earthwork operations.

3.2 MATERIALS

3.2.01 BACKFILL AND FILL

Engineer approved soil materials free of topsoil, rock or gravel larger than two inches (2") in any dimension, debris, wood, waste, frozen materials, and organic matter. Materials shall be provided that will meet the compaction requirements set forth in Section 3.3.05 COMPACTION. Recycled materials and rocks larger than two inches (2") in any dimension must be approved by the Engineer prior to placement.

3.2.02 SELECT FILL

Processed or selected natural materials consisting of sand, a mixture of sand with gravel, or crushed stone, , more generally identified as pit run sand, pit run sand and gravel, and crushed stone base course, The gradation of the material shall meet the following limits:

SELECT FILL GRADATION

Sieve Size	Percentage Passing by Weight
6-inch	100
3-inch	85
No. 4	25

3.2.03 GEOTEXTILES

- A. Beneath Pavement.** Construction fabric shall be a pervious sheet of woven fabric into a uniform pattern with distinct and measurable openings. Geotextile shall be Mirafi 600X or equal. Any alternative fabric must have the Engineer's approval prior to use.
- B. Beneath Riprap.** Geotextile fabric shall be non-woven Type HR and shall be provided in accordance with Section 645 of the WisDOT Specifications.

3.2.04 RIPRAP

Unless noted otherwise on plans, riprap shall be provided and shall be underlined with a geotextile fabric. Furnish a durable field or limestone that is angular, sound, dense and resistant to weathering. The materials shall conform to the requirements of Section 606 of the WisDOT Specifications or as directed by the Engineer. Articulated concrete block systems may also be used as appropriate.

3.2.05 TOPSOIL

Humus bearing soil, commonly known as black dirt, free of subsoil, clay, lumps, stones, and other objects over two inches (2") in diameter, and without weeds, roots, and other objectionable materials.

3.2.06 SEED

- A. Turf Grass Seed Mix.** Seed mixture shall match the following chart or approved equal and be seeded at a rate of 5 lbs./1000s.f.

Common Name	% by weight
Grasses	
Turf-Type Perennial Ryegrass	30.0%
Kentucky Bluegrass	70.0%
	100.00%

- B. Ditches.** Seed mixture shall be No. 40 per Section 630.2 of the WisDOT Specifications.
- C. Stormwater facilities.** The entire stormwater outlot shall be seeded with native vegetation. In addition to the seed mixes specified below, all disturbed areas shall also be seeded with an Annual Rye.

Ponds. The safety shelf shall be seeded with Agrecol Wetland Emergent (or approved equal). Pond banks shall be seeded with Agrecol Infiltration Swale seed mix (or approved equal) from the permanent pool elevation to 3-vertical feet above the permanent pool elevation. Above that elevation, use Agrecol Shortgrass Prairie for Medium Soils (or approved equal).

Infiltration Basins. The basin bottom shall be seeded with Agrecol Rainwater Renewal Mix (or approved equal). Banks shall be seeded with Agrecol Shortgrass Prairie (or approved equal). See the "Median Rain Garden" section for any infiltration areas placed within median roadways or terraces.

Bioretention Basins. The basin bottom shall be planted with native plugs. Permeable, biodegradable, matting with pre-germinated native plants (i.e. native vegetated mat) may be used in place of plugs and mulch for the basin bottom. Selected plant species shall be native to the region, salt tolerant, and amenable to basin conditions including extended wet periods. Banks shall be seeded with Agrecol Shortgrass Prairie (or approved equal). See the "Median Rain Garden" section for any infiltration areas placed within median roadways or terraces.

Median/Terrace Rain Gardens. Median infiltration areas will require a custom native seed mix with a height no higher than 3.5-ft mature stature. Mix shall include at least 12 different wildflowers composing at least 40% of the seed mix (by weight). Mix to be approved by the Environmental Engineer.

3.2.07 FERTILIZER

Fertilizer shall be Type B per Section 629 of the WisDOT Specifications.

3.2.08 MULCH

- A. Cellulose Mulch.** Mulch shall be cellulose hydraulic fiber mulch as approved by Engineer.

- B. **Loose Straw Mulch.** Loose straw mulch shall be derived from wheat, oats, rice, or barley and shall be weed-free. Weed-free hay derived from native grasses is also acceptable. Use of hay derived from alfalfa is not allowed.

3.2.09 EROSION MAT

- A. **Non-Channel Matting.** Erosion mat shall be selected based on slope. For slopes less than 4:1, erosion mat shall meet Type I, Urban, Class A for non-channel areas. For slopes 4:1 and greater erosion mat shall meet Type I, Urban, Class B for non-channel areas. Selected matting must be included in the Wisconsin Erosion Control Product Acceptability List. Erosion mat for non-channel areas shall be secured with a biodegradable plastic erosion mat stakes a minimum of six (6") inches in length with a barbed head.
- B. **Channel Matting.** Type II, Class C (Coirmat 780 or approved equal) for channel areas. Erosion mat for channel areas shall be secured using round top metal staple with a minimum of eight (8") inches in length and 11 GA.
- C. **Turf Reinforcement Matting (TRM).** Turf reinforcement mat shall be used for basin spillways. TRM shall be PYRAMAT 75 or approved equal.

3.2.10 RETAINING WALLS

- A. **Boulder Wall.** The boulders shall be round fieldstone. The stone shall consist of varying sizes and weights. The minimum weight shall be 250 pounds.
- B. **Modular Block Wall.**
 - 1. Masonry units shall be Keystone Retaining Units, or equal, as manufactured by Madison Block and Stone in accordance with ASTM C90 and ASTM C140.
 - 2. Masonry units shall have a minimum 28-day compressive strength of 3,000 psi. The concrete shall have a maximum moisture absorption of 8%.
 - 3. Standard units shall be classic straight split face, 8 inches high by 18 inches wide. Top row of units shall have a smooth face. Color of units to be selected by Owner.
 - 4. Connecting pins shall be 1/2-inch diameter thermoset isophthalic polyester resin-potruded fiberglass reinforcement rods. Pins shall have a minimum flexural strength of 128,000 psi and short beam shear of 6,400 pounds per ASTM D4475.
 - 5. Base levelling pad material shall be 6 inches of compacted crushed stone, 3/8 inch to 3/4 inch. Pea gravel shall not be allowed.
 - 6. Unit fill shall be free draining, well graded crushed stone, 3/8 inch to 3/4 inch, with no more than 5% passing the No. 200 sieve.

3.3 EXECUTION

3.3.01 SITE CLEARING

- A. **General.** Remove tree, shrubs, grass and other vegetation, improvements, or obstructions interfering with installation of new construction. Remove such items elsewhere on site or premises as specifically indicated. Remove and legally dispose of all stumps and roots that are not suitable for backfill material within the right-of-way.

When removing trees, special care shall be taken so as not to damage surrounding private property.

Trees and shrubs marked for removal on the plans shall not be replaced. Contractor shall replace all other removed and damaged trees, bushes and shrubs within the project limits with new stock at Contractor's expense. New trees shall be located as requested by Engineer. If the bush or shrub is damaged, or dies after restoring, Contractor shall replace it with one of same kind and size up to a height of four feet (4'). Bushes and shrubs beyond this height shall be replaced with one of same kind and height of four feet (4').

- B. Tree Protection.** Carefully and cleanly cut roots and branches of trees indicated to be left standing, where such roots and branches obstruct new construction see Section 1.2.15 TREE PROTECTION.

Trees which are damaged during construction shall be repaired. Contractor shall retain the services of a professional nurseryman who is a member of the National Arborist Association to direct them on the proper repair of damaged trees. Damaged limbs and roots shall be pruned or dressed according to recommendations of the nurseryman. Backfill shall be replaced as soon as possible to reduce exposure of roots to air. Scarfed areas on trees shall be suitably dressed.

- C. Topsoil Stripping.** Strip topsoil to whatever depths encountered in a manner to prevent intermingling with underlying subsoil or other objectionable material.

1. Remove heavy growths of grass from areas before stripping.
2. Where trees are indicated to be left standing, stop topsoil stripping at drip line of tree to prevent damage to main root system unless directed otherwise by the Engineer.

Stockpile topsoil in storage piles in areas shown, or where directed. **Stockpiles shall be immediately seeded with temporary seed mix.** Construct storage piles to freely drain surface water. Cover storage piles if required to prevent wind-blown dust.

3.3.02 EXCAVATION

Unless otherwise specified with appropriate bid items, excavation is unclassified, and includes excavation to subgrade elevations indicated, regardless of character of materials and obstructions encountered.

When excavation has reached required subgrade elevations and all utility crossings have been installed, notify the Engineer who will make inspections of conditions. Engineer shall check subgrade elevations and verify all utility crossings have been installed. Once subgrade elevations are correct and all crossing have been installed, Engineer shall perform a test roll prior to placement of base course. If unsuitable bearing materials are encountered at required subgrade elevations, Contractor shall carry excavations deeper and replace excavated material as directed by Engineer.

Base course placed on unstable foundation shall be removed and replaced following undercut of the affected area, all at Contractor's expense.

Undercut areas shall be backfilled with breaker run material per SECTION 5 - PAVEMENTS and, where requested by Engineer in the field, shall be lined with geotextile

material. 1:1 tapered edges shall be provided for all undercut areas as directed by Engineer. Undercut shall be carried through utility trench when directed by the Engineer. Slope sides of excavations shall comply with local codes and ordinances having jurisdiction. Shore and brace where sloping is not possible because of space restrictions or stability of material excavated.

Maintain sides and slopes of excavations in safe condition until completion of backfilling.

Stockpile satisfactory excavated materials where directed until required for backfill or fill. Place, grade and shape stockpiles for proper drainage.

All abandoned private utility pipes that are exposed during excavation shall be plugged with concrete, unless directed otherwise by the private utility owner. Contractor shall notify Engineer and obtain approval of abandonment prior to backfilling.

Locate and retain soil material away from edge of excavations. Do not store within drip line of trees indicated to remain.

- A. Excavation for Structures.** Conform to elevations and dimensions shown within a tolerance of plus or minus 0.10', and extending a sufficient distance from footings and foundations to permit placing and removal of concrete form work installation of services, other construction, and for inspection.
- B. Excavation for footings and foundations.** In excavating for footings and foundations, take care not to disturb bottom of excavation. Excavate by hand to final grade just before concrete reinforcement is placed. Trim bottoms to required lines and grades to leave solid base to receive other work.
- C. Pulverize Pavement.** Contractor shall pulverize the full-depth existing asphalt surface. The pulverized material shall be used as part of the road base. Any surplus grindings shall be hauled to a City designated site, by the Contractor. All limits for the pulverized area shall be sawcut to provide butt joints at intersecting streets and driveways.

3.3.03 DISPOSAL OF WASTE MATERIALS

Remove waste materials and unsuitable and excess topsoil from Owner's property and dispose of off-site in a legal manner. Burning on Owner's property is not permitted, unless approved by the City.

3.3.04 BACKFILL AND FILL

Place acceptable soil material layers to required subgrade elevations, for each area classification listed below. Contractor shall backfill excavations as promptly as work permits.

- A.** In excavations, **if not defined elsewhere**, use satisfactory excavated or borrow material.
- B.** Under grassed areas, use satisfactory excavated or borrow material.
- C.** Under walks, pavements and Right-of-Way, **as well as within their zone of influence**, use select fill for the first three feet (3') below pavement surface and satisfactory excavated or borrow material below the first three feet (3') that will meet the compaction requirements.
- D.** Under building **slabs and adjacent to foundation walls as well as within their zone of influence** use select fill material.

3.3.05 COMPACTION

Control soil compaction during construction providing minimum percentage of density specified for each area classification.

Compact soil to not less than the following percentages of maximum dry density for soils which exhibit a well-defined moisture density relationship (cohesive soils) determined in accordance with ASTM D 1557; and not less than the following percentage of maximum dry density, determined in accordance with ASTM D 2049, for soils which will not exhibit a well-defined moisture-density relationship (cohesion less soils).

- A. Walkways and Pavements.** Compact top three feet (3') of backfill and/or fill material at 95% maximum dry density and all layers below three feet (3') at 90% maximum dry density.
- B. Structures.** Compact fill and/or backfill material at 95% maximum dry density.
- C. Lawn or Unpaved Areas.** Compact top six inches (6") of subgrade and each layer of backfill or fill material at 85% maximum dry density for cohesive soils and 90% maximum dry density for cohesionless soils.
- D. Pulverized Pavement.** To achieve compaction, Contractor shall water and roll the pulverized material using a vibrating roller.

Where subgrade or layer of soil material must be moisture conditioned before compaction, uniformly apply water to surface of subgrade, or layer of soil material. Apply water in manner to prevent free water appearing on surface during or subsequent to compaction operations.

Where subgrade or layer of soil material is too moist remove and replace, or scarify and air dry, to permit compaction to specified density. Soil material that has been removed because it is too wet to permit compaction may be stockpiled or spread and allowed to dry. Assist drying by disking, harrowing or pulverizing until moisture content is reduced to a satisfactory value.

3.3.06 GEOTEXTILES AND GEOGRID

Geotextiles and geogrid shall be placed as requested by the Engineer to stabilize subgrade areas. Construction fabric shall be installed in accordance with the manufacturer's recommendations.

3.3.07 DEEP TILLING

Prior to final landscaping, the soil structure of all areas that have been compacted by construction equipment shall be restored to pre-construction conditions by deep tilling with a ripper or similar tool followed by chisel plowing or similar methods. The cuts shall be made on the contours, perpendicular to the direction of surface water flow. The depth of tilling shall be at least 2 inches below the hardpan layer or compacted zone, as determined by a soil probe or soil penetrometer, up to a maximum depth of 36 inches. The maximum spacing of the ripper cuts shall be 5 feet. Ripping shall be followed by chisel plowing to a depth of 12 inches. In cases where the depth of the hardpan layer or compacted zone is less than 10 inches, chisel plowing alone may be used without prior ripping.

3.3.08 TOPSOIL

Topsoil shall be placed and spread at a uniform depth. If no depth is shown, place and spread topsoil to a minimum depth of six inches (6").

3.3.09 FINE GRADING

Uniformly grade areas that are called out for restoration. Break down all clods and lumps within the topsoil, using the appropriate equipment, to provide a uniformly textured soil. A smooth finished surface shall be provided within a tolerance of plus or minus one-half inch (+/- 1/2").

3.3.10 SEED RESTORATION

All areas disturbed by grading, street, utility, curb and gutter, and sidewalk construction, shall be restored. Backslopes adjacent to the sidewalk shall be seeded to the slope intercept.

Turf grass seeding shall be performed in accordance with Method A or a modified Method B of Section 630 of the WisDOT Specifications and applied at a rate of 5 lb./1000 sf.

Hydromulching shall be performed in accordance with Method B, of Section 630 of the WisDOT Specifications, modified to include a mulching material. Mulch shall be applied in at least two directions at a rate of 2,000 pounds per acre.

Native seeding shall be performed and applied at a rate in accordance with manufacturer specifications.

For restoration of areas under 50 square feet, loose straw may be hand scattered uniformly over the seeded area in lieu of hydromulching.

3.3.11 EROSION MAT

All erosion mat shall be secured according to manufacturer's specifications or the following, whichever is more restrictive. Class I, Urban Type A, and Class I, Urban Type B erosion mat shall be secured with a minimum 1.75 staples per square yard. Spacing of any single staple shall not be more than three feet (3') from an adjoining staple. Class II, Type C mat shall be secured with a minimum of 8 staples per square yard. Spacing shall not be more than two feet (2') from an adjoining staple. Erosion mat is necessary for all slopes steeper than 5:1 with class of mat specified by Engineer. Class II, Type C mat shall extend a minimum of two feet vertically up channel side slopes. Turf Reinforcement Mat shall be installed and anchored per manufacturer's specifications beneath a 1-inch layer of topsoil and overlaid with Class I, Urban Type B matting.

3.3.12 STORMWATER FACILITIES

A. Infiltrative Practices. Infiltrative practices (such as bioretention basins and infiltration basins) shall be constructed in accordance with Dane County / Green Tier's "Infiltration Practice Construction Guidance" document, available at: <https://wred-lwr.dane.gov/documents/Stormwater/Infiltration-Practice-Construction-Guidance.pdf>.

A geotechnical engineer shall be on site during construction of infiltration practices to verify construction of practice, all materials used, and native soils. Documentation from this professional shall be required as part of the As-Built Certification.

Engineered soil shall be mixed off site.

Deep till native soils prior to placing imported materials on top, if applicable. After final grading of infiltration practice, deep till the entire practice prior to restoration upon Engineer's discretion.

- B. Retention Ponds.** Retention ponds that are to be used as sedimentation basins during construction shall be excavated two (2) feet below plan grade of the basin bottom.

3.3.13 RETAINING WALLS

- A. Boulder Wall.** In areas as generally shown on the drawings and as specifically noted in the field by the Engineer, contractor shall construct boulder retaining walls.

The stone shall be placed randomly. The larger stone shall be placed at the bottom. The minimum batter shall be three inches (3") in one vertical foot unless otherwise allowed by Engineer. Geotextile fabric shall be installed behind the wall to prevent the backfill from eroding through the joints and courses. Backfill shall meet the requirements of Section 209 of the WisDOT Specifications. The layout of the wall shall be approved by Engineer prior to construction of the wall. A suitable foundation, as approved by Engineer, shall be provided to preclude settlement. The wall may be constructed in conjunction with the new embankment. Some chinking may be required to secure stability of the stones.

- B. Modular Block Retaining Wall.** Modular wall units shall be constructed in accordance with the following standards:

- ASTM C90 - Load Bearing Concrete Masonry Units.
- ASTM C140 - Sampling and Testing Concrete Masonry Units.
- ASTM D4475 - Apparent Horizontal Shear Strength of Pultruded Reinforced Plastic Rods by the Short-Beam Method.
- ASTM D2339 - Strength Properties Adhesives in Two-Ply Wood Construction in Shear by Tension Loading.

The first course of wall units shall be placed on the base levelling pad. The units shall be checked for level and alignment. Bottom of wall shall be a minimum of 12 inches below finished grade.

Units shall be placed side by side for full length of wall alignment. Alignment may be done by a string offset or offset from sidewalk.

Units shall be interlocked with noncorrosive fiberglass pins. Pins shall protrude into adjoining courses above a minimum of one inch (1"). Two pins require per unit.

Unit fill shall be placed directly behind the wall to a minimum width of 12 inches.

All voids inside and between units and drainage zone behind units shall be filled with tamped unit fill material.

All capstone block shall be attached with the adhesive per the manufacturer's instructions.

3.3.14 MAINTENANCE

Protect newly graded areas from traffic and erosion. Keep free of trash and debris. Repair and re-establish grades in settled, eroded, and rutted areas to specified tolerances.

Where settling is measurable or observable at excavated areas during general project warranty period, remove surface (pavement, lawn or other finish), add backfill material, compact, and replace surface treatment. Restore appearance, quality, and condition of surface or finish to match adjacent work, and eliminate evidence of restoration to greatest extent possible.

3.3.15 RIPRAP

Riprap shall be underlined with a geotextile fabric and shall be placed at the ends of pipe outfalls as shown on the plans or as directed by the Engineer in accordance with Section 606 of the WisDOT Specifications. Geotextile fabric shall be installed per the manufacturer's recommendations and in accordance with Section 645 of the WisDOT Specifications. Geotextile fabric shall extend a minimum of two feet (2') under apron endwalls. Riprap shall extend to the spring line of the endwall. Substitution of recycled concrete for riprap is prohibited. See Standard Detail Drawing 6.06.

3.3.16 UTILITY LINE OPENINGS (ULO's)

This work consists of excavating to uncover utilities for the purpose of determining elevation and potential conflict as shown on the plans or as directed by the Engineer in the field. The excavation shall be done in such a manner that the utility in question is not damaged, and the safety of the workers is not compromised. The utility line openings shall be performed as soon as possible and at least three (3) days in advance of proposed utility or street construction to allow any conflicts to be resolved with minimal disruption. All utility line openings shall be approved and coordinated with the Engineer. Steps for basic potholing:

- a. Saw cut pavement full-depth with a bit 12" to 16" in diameter resulting in a "core".
- b. Remove core and save for reuse if structurally sound.
- c. Place a protective steel ring to protect the edge of the opening from damage.
- d. Use vacuum equipment to excavate compacted material from the bottom of base course to beneath the utility facility.
- e. Perform utility work (e.g., watch bore head, leak repair, service connection).
- f. Protect utility facility with fine material.
- g. Place self-mixing flowable fill material from the top of the fine material to bottom of the base course (fill is designed to be traffic-bearing in ~90 minutes).
- h. Place non-shrink grout (grout is designed to be traffic-bearing in ~90 minutes).
- i. Place the removed core (or a generic equivalent replacement core) in the remaining opening (original alignment and orientation is maintained if removed core is used) forcing the grout to the surface to fill the annular space and core extraction hole.
- j. Seal the restored opening.

END

SECTION 4 - CONCRETE AND CONCRETE STRUCTURES

4.1 GENERAL

4.1.01 RELATED DOCUMENTS

WisDOT Specifications, latest revision available at
<https://wisconsindot.gov/Pages/doing-bus/eng-consultants/cnslt-rsrces/rdwy/stnds-spec.aspx>

4.1.02 DESCRIPTION OF WORK

This section includes the provision and placement of concrete for curb and gutter, traffic medians, sidewalk, concrete driveways and related appurtenances including detectable warning fields.

4.2 MATERIALS

4.2.01 CONCRETE

Concrete materials shall be provided in accordance with the requirements of Section 501 of the WisDOT Specifications.

The concrete shall be six (6) bag, air-entrained concrete as supplied by a reputable ready-mix supplier and be designed to obtain 4,000 psi in 28 days.

All concrete shall be air-entrained and shall contain seven (7) percent air by volume, plus or minus 1.5%.

Special High Early Strength (SHES) concrete shall conform to Section 416 of the WisDOT Specifications.

Addition of water to concrete on site is prohibited.

Mix design adjustments may be requested by Contractor when characteristics of materials, job conditions, weather, test results, or other circumstances warrant; at no additional cost to Owner and as accepted by Engineer. Laboratory test data for revised mix design and strength results must be submitted to and accepted by Engineer before using in work.

Colored concrete:

- a. Concrete color for cycle tracks shall be "DCS Green w/ Grey Cement #100" or as approved by Engineer.
- b. Concrete color for medians and decorative terraces shall be "Red Brick" or as approved by Engineer. Stamp shall be 4" x 8" running bond pattern perpendicular to curb.
- c. Concrete color for Roundabouts shall be "DOT Red" or as approved by Engineer.

4.2.02 EXPANSION JOINT FILLER MATERIAL

One-half inch (1/2") expansion joint filler shall be furnished in lengths equal to the joint width and to the thickness and height that is required. Use of multiple filler sections at a joint, street light base, valve box, or manhole to achieve required length, height, and/or thickness is prohibited.

Expanded polyolefin (EpoFoam) joint filler to be used around all valve boxes, light bases, manholes and hydrants in the concrete. Seal the top ¼" with manufacturer specified NP-1 Sonoelastic caulk.

4.2.03 DETECTABLE WARNING FIELDS

Detectable warning fields shall be Neenah Foundry's Detectable Warning Plate R-4984, natural finish or approved equal cast iron plate. The detectable warning fields shall consist of a combination of panels to meet the specified length and width for the warning field area. The color of the detectable warning fields shall be natural patina.

Radial plates shall be from the WisDOT manufacturer's approved list. The Contractor shall select the appropriate radial plate radius that matches the intersection radius design.

4.2.04 SIGN BASE

All signs in concrete shall utilize an eight-inch (8") V-Loc (23-VR1) and wedge for a 2-3/8" galvanized steel post for the base.

4.3 EXECUTION

4.3.01 GENERAL CONCRETE

Placement of concrete shall conform to the requirements of Section 415 of the WisDOT Specifications.

Deposit and consolidate concrete slabs in a continuous operation, within limits of construction joints, until the placing of a panel or section is completed.

Consolidate concrete during placing operations so that concrete is thoroughly worked around reinforcement and other embedded items and into corners.

Bring slab surfaces to correct level with straightedge and strike off. Use bull floats or darbies to smooth surface, free of humps or hollows. Do not disturb slab surfaces prior to beginning finishing operations.

All exposed non-colored concrete surfaces shall be protected during curing with a white pigmented curing compound. All colored concrete surfaces shall be protected during curing with clear curing compound.

When sawcutting joints in concrete, the minimum depth of the joint shall be ¼ of the depth of the concrete slab.

Concrete, except curb ramps and bike path ramps, to be removed and replaced shall be sawcut at the nearest existing joints. Install two (2) #4 epoxy coated tie bars, 12 inches (12") in length, extending six inches (6") into the existing and the new concrete at the joints unless directed by the Engineer. Tie bar spacing shall be as directed by Engineer. Curb ramps and bike path ramps to be removed and replaced shall be removed and replaced in their entirety unless directed otherwise by Engineer.

No concrete work may take place while it is raining. All concrete poured during rain events shall be removed and replaced at Contractor's expense. Altering visually damaged concrete is not acceptable i.e. brushing.

Use of Contractor name stamp to mark concrete for permanent identification is prohibited.

24 hours prior to working Contractor shall notify adjacent property owners of concrete operations.

All concrete washouts shall be conducted in the designated location, or at location approved by Engineer.

Valve box top section, per Section 7, with two 8"x8"x2" concrete block supports, one on each side of the valve box top section, shall be installed over curb stops within concrete surfaces. Curb stop box shall be set two inches below top of valve box.

4.3.02 CURB AND GUTTER

Minimum base course depth beneath curb and gutter shall be six inches (6").

The top of the curb shall be marked where the sanitary sewer lateral, water service, and City owned fiber optic and electrical conduit cross the curb and gutter. The mark may be made by stamping. The depth shall be a minimum of one-sixteenth (1/16") inch deep. A "W" shall be stamped over each water service crossing, an "S" shall be stamped over each sanitary lateral crossing, an "F" shall be stamped over each City fiber optic crossing, and an "E" shall be stamped over each City electric conduit crossing.

Beginning three feet (3') on both sides of inlets, curb and gutter shall be poured manually with an eight inch (8") flow line depression from the top of curb along the inlet tapered from the typical six inch (6") flow line. Concrete shall be poured behind the inlet casting so as to cover the bolt holes. Place a seven foot (7') long epoxy coated #4 reinforcing rod in concrete gutter in front of inlet as directed by Engineer.

Provide one-half inch (1/2") expansion joint filler everywhere that a tangent and radial curb and gutter meet; on each side of every inlet 3 feet from the inlet, but no closer than 6 feet from another joint; and on tangent sections place between 6 feet and 300 feet.

When placing curb and gutter adjacent to sidewalks and driveways install one-half inch (1/2") expansion joint filler between the two structures for the entire length and depth.

After curb and gutter is poured, backfill material shall be placed and compacted behind curb prior to placement of additional base course once concrete has achieved a minimum compressive strength of 3,000 psi.

Permanent plow ramps shall taper over six feet (6') in length when curb and gutter ends. All stub streets shall have three foot (3') plow ramps.

4.3.03 INTEGRAL ISLAND NOSE

All median island noses shall be poured integral with the curb and gutter. Noses shall be a minimum of six feet (6') in length from front of curb to back of nose.

Where identified on the plans or directed by the Engineer, median noses shall include a V-Loc and wedge for a 2-3/8" galvanized steel post to be placed into the concrete nose. V-Loc shall be flush with concrete, unless authorized by the Engineer.

4.3.04 SIDEWALK

Topsoil shall be stripped prior to placement of the base material for the sidewalk.

Base for concrete sidewalk shall consist of a minimum of four inches (4") of ¾-inch dense graded crushed stone or gravel as specified in SECTION 5 - PAVEMENTS AND BASE COURSE.

Expanded polyolefin joint filler shall be placed around all street light bases, valve boxes, hydrants and manholes located within concrete sidewalk surfaces. Seal the top ¼" with manufacturer specified NP-1 Sonoelastic caulk.

Provide half-inch (1/2") expansion joint fillers at all ramp locations, between sidewalk and driveway aprons, between sidewalk and abutting parallel curb and gutter, between sidewalk and buildings or other rigid structures, and at all radii. Transverse expansion joint filler shall be placed through the sidewalk at uniform intervals of not more than 96 feet.

Generally, concrete thickness for public sidewalks shall be five inches (5"). Concrete thickness for curb ramps, bike path ramps, and sidewalk or bike path across driveway openings shall be seven inches (7").

Forms shall be equal to or greater than the sidewalk thickness. The Engineer may make exceptions to this at a radius. Metal forms shall be used as often as practical.

See Standard Detail Drawing 4.02 Sidewalks and Paths

4.3.05 CYCLE TRACK AND CONCRETE MULTI USE PATH

Cycle tracks and concrete multi-use path shall be installed per sidewalk requirements. All joints shall be sawcut at 1/8 inch in width and, where applicable, line up with adjacent concrete joints.

4.3.06 DETECTABLE WARNING FIELDS

Detectable warning fields are required where a sidewalk or bike path crosses a vehicular way (excluding driveways), where a rail system crosses pedestrian facilities that are not shared with vehicular ways, at reflecting pools within the public right-of-way, which do not have curb or rim protruding above the walking surface, at islands and medians that are cut through level with the roadway, and at any other location required by Engineer.

Detectable warning fields for sidewalk and bike path ramps shall extend 24 inches in the direction of the pedestrian travel and shall extend the full length of the curb ramp or flush surface, a minimum of five feet (5') for sidewalk ramps and a minimum of ten feet (10') for bike path ramps. When possible detectable warning fields shall be flush to the felt on the back of curb for straight approaches.

Voids may not exist between the detectable warning field and concrete. In the event voids exist, the warning plate and concrete shall be removed and replaced. Slurry or caulk repairs are not permitted.

See details for guidance on when to use radial field plates. When selecting radial plates, slight variance of up to 3 feet between the radii of the detectable warning field and the back of curb will provide a uniform concrete border between back of curb and radial field. A maximum 3-inch concrete border is allowable between the back of curb and radial detectable warning field, with the concrete border width variable up to 1 inch.

When radial detectable warning fields are used, the outermost radial plates will not coincide with the curb ramp edges. The outermost radial plates will need to be field cut to match the curb ramp edges. Develop construction details of each curb ramp, including the layout of individual full-size radial plates as well as flanking cut radial plates. Field-cut plates cannot

be shorter than 6 inches along any cut edge. Depict full-size radial plates within the interior of the curb ramp layout, as intermediate joints within the warning field must not be field cut. The radial plate final field placement may vary, as the contractor will determine the final warning field configuration and its individual plate locations.

4.3.07 DRIVEWAYS

All commercial driveways located along a roadway with curb and gutter shall conform to these specifications unless specifically permitted otherwise by the Engineer.

Concrete thickness for driveway aprons shall be seven inches (7") and the crushed aggregate base thickness shall be a minimum of four inches (4").

Provide one-half inch (1/2") expansion joint filler against sidewalks and curb and gutter,

For residential and commercial driveway openings along streets with existing curb and gutter, the contractor shall either remove and replace existing curb and gutter at the driveway opening per specifications or make a 'profile curb cut' in which the curb head is cut with a concrete saw specifically designed for this type of work.

4.3.08 PROTECTION OF CONCRETE

A. General. Contractor shall erect and maintain suitable barricades to protect the new concrete. Where it is necessary to provide for pedestrian traffic, the Contractor shall, at their own cost, construct adequate crossings as shown on the drawings or as specified. Crossing construction shall be such that no load is transmitted to the new concrete.

Any part of the work damaged, undermined, or vandalized prior to final acceptance shall be repaired or replaced at the expense of the Contractor as directed by the Engineer.

Apply curing compound as soon as the concrete is dry to the touch and will not be marred from stepping on it. If curing compound is not applied, concrete must be cured with plastic until strength of 3,000 psi is achieved or for seven (7) days, whichever comes first. Removal of plastic, whether temporary or permanent, during this time, is prohibited.

Construction activities and vehicular traffic shall not be permitted adjacent to or over newly placed concrete until a minimum compressive strength of 3,000 psi has been achieved.

B. Cold Weather Protection. Protect concrete work from physical damage or reduced strength which could be caused by frost, freezing actions, or low temperatures, in compliance with ACI 306, WisDOT Specifications, and as herein specified.

At any time of the year, if the National Weather Service forecast for the construction area predicts freezing temperatures within the next 24 hours, or when freezing temperatures actually occur, provide the minimum level of thermal protection specified below for concrete that has yet to conform to the opening criteria specified in WisDOT 415.3.15. Protection shall remain until minimum strength requirements are met. Polyethylene sheeting shall conform with WisDOT 501.2.8 (4 mil minimum thickness per layer).

Predicted or Actual Air Temperature Minimum Equivalent Level of Protection
22 to <28 F single layer of polyethylene
17 to <22 F double layer of polyethylene
<17 F 6" of loose, dry straw or hay between two layers of polyethylene

Unless written approval is provided by the Engineer, suspend concreting operations if the descending air temperature in the shade and away from artificial heat falls below 35 degrees Fahrenheit. Do not resume concreting operations unless temperatures in the shade and away from artificial heat reaches 32 degrees Fahrenheit and is rising. At all times the concrete temperature at the point of placement shall be above 50 degrees Fahrenheit.

Contractor shall be responsible for the protection of the concrete placed. Any concrete damaged by freezing or frost action during the first seven (7) days following its placement shall be removed and replaced by the Contractor at Contractor's expense.

Calcium chloride, salt and other materials containing antifreeze agents or chemical accelerators shall not be used, unless otherwise accepted in mix designs.

- C. **Hot Weather Protection.** When hot weather conditions exist that would seriously impair quality and strength of concrete, place concrete in compliance with American Concrete Institute ACI 305.

4.4 **FIELD QUALITY CONTROL AND TESTING**

4.4.01 **TESTING**

Owner will be responsible for concrete testing. Contractor shall coordinate testing with the Owner. This includes retesting of rejected materials or completed work.

END

SECTION 5 - PAVEMENTS AND BASE COURSE

5.1 GENERAL

5.1.01 RELATED DOCUMENTS

WisDOT Specification, latest revision available at
<https://wisconsin.gov/pages/doing-business/eng-consultants/cnslt-rsrcs/rdwy/stnds-spec.aspx>

- Omit the following sections
 - 450.3.2.1.2 Cold Weather Paving
 - 450.3.2.11 Safety Edge
 - 455.2.2 Sampling
 - 455.2.3 Testing
 - 460.2.8 Quality Management Program
 - Section 740 QMP Ride

5.1.02 DESCRIPTION OF WORK

This section includes requirements for the provision and placement of base course, asphaltic pavement, and pavement markings.

5.1.03 SCHEDULE

Unless specified differently, all upper layer paving shall be complete by September 15 and all lower layer paving shall be completed by October 31. Only patching will be allowed after these dates as approved by the Engineer.

5.1.04 SUBMITTALS

Prior to paving the following items, shall be submitted to Engineer for approval.

- HMA Mix design meeting the specifications of Section 1.2.04 SHOP DRAWINGS for each applicable roadway/pavement type
- Regression of air voids documentation, along with newly calculated %AC, VMA, VFB, and Gmb
- RAS Stockpile production samples, if RAS is used in the mix design

5.2 MATERIALS

5.2.01 CRUSHED AGGREGATE BASE COURSE

The aggregates shall consist of hard, durable particles of crushed stone resulting from the artificial crushing of rock, boulders, or large cobblestones substantially all faces of which have resulted from the crushing operation. The material shall be free from dirt, asphalt, debris, frozen materials, organic matter, shale and lumps or balls of clay.

The determination of the acceptability of the aggregates will be made by visual observation and/or laboratory test. The Engineer reserves the right to prohibit the use of material from any source, plant, pit, quarry, or deposit where the character of the material or method of operation is not furnishing aggregate that conforms to the requirements of these Specification, unless satisfactory evidence is shown that material conforming to the specification requirements is produced.

NOTE: The City shall be notified 24 hours prior to the placement of base course. In giving this notice, the Contractor shall indicate the source for the base course. If during rocking operations the source changes, the City must be notified. The Contractor takes on the financial responsibility of placement of the base course from the new source if the material is unsuitable.

Unless specified differently, base course thickness shall be twelve-inches (12") consisting of three-inch (3") dense in the bottom seven to eight inches (7"-8") and one and one-quarter inch (1-1/4") dense in the top four to five inches (4"-5"). Gradations shall conform to the requirements of Section 305 WisDOT Specifications or as directed by the Engineer.

5.2.02 UNSCREENED BREAKER RUN STONE

The materials shall conform to the requirements of Section 311 WisDOT Specifications or as directed by the Engineer.

5.2.03 BREAKER RUN MATERIAL

The materials shall conform to the requirements of Section 311 WisDOT Specifications or as directed by the Engineer. Engineer reserves the right to require modifications to the material, if material does not contain sufficient gradation to eliminate voids, does not provide adequate 5" to 6" material to provide structural support, and/or contains too many fines. The material shall be free from dirt, asphalt, concrete, debris, frozen materials, organic matter, shale and lumps or balls of clay.

5.2.04 FLOWABLE FILL

Flowable fill shall be excavatable, having strength greater than 200 psi but not exceeding 300 psi. The following flowable fill mix design is recommended.

FLOWABLE FILL MIX DESIGN		
Material	Unit	Quantity
Sand	lb.	3000
Water	Gal.	43
Fly Ash	lb.	200
Air Content	%	25 - 30
Cement	lb.	50

5.2.05 ASPHALTIC PAVEMENT

Refer to WisDOT Specifications, Sections 460.2.1 – 460.2.7 and 460.3.2 except wherein modified or appended:

HMA mix design shall be the following unless otherwise specified in the Special Provisions.

ASPHALT MIX TYPES		
HMA Type	Asphalt Material	Roadway Type
MT	58-28	Arterial
MT or LT	58-28H	Roundabouts & Turn Lanes*
LT	58-28	Collector & Residential
LT	58-28	Shared-use paths
LT	58-28	Tennis Court / Basketball Court

*Surface Only

ASPHALT MIX THICKNESS			
Nominal Maximum Aggregate Size (NMAS)	Use	Minimum Layer Thickness (in)	Maximum Layer Thickness (in)
3	Lower Layer	2.25	4.0
4	Lower Layer	1.75	3.0
5	Upper Layer	1.5	3.0
5	Basketball / Tennis Courts/ Shared-use Path	1.5	3.0

Lower layer shall be asphalt mix gradation 4 and upper layer shall be asphalt mix gradation 5. The lower layer may be asphalt mix gradation 3 where the lower and upper layers are applied in the same calendar year.

All HMA mix designs for Arterial, Collector, Residential and Shared Use Paths shall have a target of 3.0% air voids. This shall be accomplished by taking an existing mix design that targets 4.0% air voids and increasing the asphalt content to achieve 3.0% air voids. New VMA, VFA and Gmb JMF targets will be recalculated with the new Asphalt Content.

5.2.06 ADJUSTING RINGS

Non-rocking Neenah cast iron adjusting rings or approved equal. Neenah Reference No. 1550-7151 for 1-1/2" adjusting rings and No. 1550-7201 for two inch (2") adjusting rings.

5.2.07 TACK COAT

Type MS-2, SS-1, SS-1h, CSS-1, CSS-1h, or an approved modified emulsified asphalt. Tack must break before paving commences.

5.2.08 PAVEMENT MARKINGS

Pavement Markings shall be epoxy paint unless otherwise directed by Engineer.

5.2.09 CYCLE TRACK

General: For areas where cycle track transitions to asphalt pavement, install high friction colored surface in accordance with manufacturers specifications. Use Color-Safe Pavement Marking with Anti-Skid Surface by Transpo Industries or an approved equal. Use an MMA based system capable of retaining an aggregate topping under vehicular traffic conditions.

The MMA based resin system shall comply with chromacity requirements in accordance with MUTCD Interim Approval for Optional Use of Green Colored Pavement for Bike Lanes.

MMA Based Resin System: The MMA based resin system shall meet the following requirements:

Property	Value	Test Method
Tensile Strength @ 7 days, psi, minimum	1000	ASTM D 638
Hardness, Shore D, minimum	80	ASTM D 2240
Gel Time, minutes, minimum	10	ASTM D 2471
Cure Rate, hours, maximum	3	Film @ 75°F
Water Absorption @ 24 hours, max	0.25%	ASTM D 570

Aggregate: The aggregate shall be high friction crushed Bauxite, Granite, or gravel. The aggregate will be delivered to the construction site in clearly labeled bags or sacks. The aggregate shall be clean, dry and free from foreign matter. The aggregate shall meet the following requirements:

Property	Value	Test Method
Aggregate Abrasion Value, Aggregate Grading,	maximum 20	LA Abrasion
No 6 Sieve Size,	minimum passing, 95%	
No 16 Sieve Size,	maximum passing, 5%	
Aggregate Color	Green	

Certification: Finished surface shall have a minimum 60 FN40R in accordance with ASTM E274 of aggregate bonded to a vehicular bearing surface using the modified epoxy binder.

5.2.10 PAVEMENT JOINT ADHESIVE

Pavement joint adhesive shall follow the below specifications unless otherwise specified in the Special Provisions.

Property	Value	Test Method
Brookfield Viscosity, 204 °C [400 °F]	4,000-10,000 cp	ASTM D 3236
Cone Penetration, 25 °C [77 °F]	60-100 dmm	ASTM D 5329
Resilience, 25 °C [77 °F]	30% minimum	ASTM D 5329
Ductility, 25 °C [77 °F]	30 cm minimum	ASTM D 113
Ductility, 4 °C [39.2 °F]	30 cm minimum	ASTM D 113
Tensile Adhesion, 25 °C [77 °F]	500% minimum	ASTM D 5329
Softening Point	77 °C [170 °F] min.	ASTM D 36
Asphalt Compatibility	Pass	ASTM D 5329

5.3 EXECUTION

5.3.01 BASE COURSE

Prior to placement of the base course, the subbase shall be test rolled within the presence of the Engineer. Give a minimum of 24-hours notice to the Engineer prior to test rolling. Base course grade shall be set to allow thickness of asphaltic pavement such that new asphalt is $\frac{1}{4}$ " above curb and gutter.

Existing roads shall match existing base course depth or twelve (12) inches, whichever is greater.

New roads shall have a minimum base course depth of twelve (12) inches or greater if required by Engineer.

Each layer of base course shall be wetted and rolled to provide maximum compaction in accordance with Section 301 of the WisDOT Specifications.

The finished base course shall be fine graded in preparation for paving.

After final grading, Contractor shall maintain the base course until asphaltic paving work has been completed. All gravel surfaces damaged during construction shall be replaced.

5.3.02 FLOWABLE FILL

Flowable fill is required at all locations where curb and gutter, sidewalks, or pavements have been undermined.

5.3.03 FINISHING ROADWAY

The finished base course shall be fine graded in preparation for asphaltic paving. Base course or asphalt ramps at all existing pavement shall be removed to provide a full depth butt joint.

5.3.04 NEW ROADWAYS

Newly constructed roadways shall, unless otherwise directed by the Engineer, receive lower layer only NMAS 4 (12.5mm). Placement of the upper layer(s) NMAS 5 (9.5mm) shall be postponed as deemed necessary by the Engineer so as to minimize damage caused by construction traffic.

Manhole castings and valve boxes in roadways temporarily receiving the lower layer only shall be set to lower layer grade. Manhole castings and valve boxes shall be set one-quarter inch ($\frac{1}{4}$ ") below final grade in all other areas unless otherwise directed by Engineer. "Scab" and monolithic ramping is prohibited.

Immediately prior to placement of upper layer(s), Contractor shall install non-rocking cast iron adjusting rings on all manholes located within the area to be paved and raise all valve boxes to one-quarter inch ($\frac{1}{4}$ ") below final grade.

5.3.05 ASPHALTIC PAVING

Prior to commencement of paving operations, Contractor shall examine the finished base course. Contractor shall notify Engineer of any areas of suspected instability. The Engineer may require an additional test roll if there is a rain event before paving commences. The

pavement structure for new roads shall be determined from the standard cross-sections encountered in the field. 24 hours prior to paving Contractor shall notify adjacent property owners of paving operations.

Engineer shall check grade of base and structure adjustments prior to paving. 48-hours notice shall be provide to Engineer prior to paving after grading and adjustments are complete.

All adjacent concrete surfaces shall be installed and have a minimum compressive strength of 3,000 psi prior to paving.

Contractor shall not pave during rain events. Contractor shall obtain approval from Engineer before commencing paving activities after rain events.

New finished asphaltic upper layer shall be one-quarter inch (1/4") above flag of adjacent curb and gutter.

All manhole castings and valve boxes within the paving limits of the street shall be adjusted to a one-quarter inch (1/4") below the finished asphaltic upper layer. Failure to meet this tolerance may require removal and replacement of the pavement, to limits determined by Engineer, at Contractor's expense.

Base course around manhole castings and valve boxes shall be hand trimmed and compacted with a vibratory plate compactor.

The Fitchburg Utility Department shall inspect their valve boxes and manholes prior to paving. Contractor shall provide two (2) days notice prior to paving to coordinate the inspection of the water valves. For City of Fitchburg Utility, call (608)270-4270.

Contractor shall furnish Class 1 barricades with flashers on all adjusted castings until paving has been completed. Tops of castings and valve boxes shall be oiled, or protected by other methods to prevent sealing of lids and filling of lift holes during paving. Upon completion of paving operations, Contractor shall check all castings and valve boxes to ensure that the lids are clean and operational.

The thickness of lower and/or upper course mixture shall be installed in one course each. The mixture shall be laid and compacted so that the average yields in pounds per square yard conform to the following chart:

<u>SURFACE & BINDER YIELD - # / S.Y.</u>		
<u>Thickness</u>	<u>Min.</u>	<u>Max.</u>
1"	112	118
1 1/2"	168	177
1 3/4"	196	206.5
2"	224	236
2 1/4"	252	265.5
2 1/2"	280	295
3"	336	354

Whenever the yields fall below the minimum allowable yields specified above, the Engineer shall determine the corrective action to be taken. The corrective action may include removal and replacement of the area of deficient thickness, an overlay with approved material of the area of deficient thickness, or such other action as the Engineer shall determine. The area of deficient thickness shall be determined on the basis of street area, or area covered in one day's operation, whichever is less. The Engineer's determination

will be based on the circumstances of the area involved, and will include a determination of the distribution of costs of the corrective work required.

When the average yield on a project exceeds the maximum allowable yield, all excess material shall be paid for at the rate of one-half, the contract unit price for the type of material involved. The average yield for this purpose shall be computed on a daily basis, or a street area, whichever covers the smallest area of paving.

Place asphalt mixture on prepared surface, spread and strike-off. Place inaccessible and small areas by hand. Place each course to required grade, cross-section, and compacted thickness.

Place asphalt in strips not less than ten feet (10') wide, unless otherwise acceptable to the Engineer. Complete lower course for a section before placing upper layer course.

Cold Weather Paving

Do not pave asphalt when the air temperature approximately 3 feet above grade, in shade, and away from artificial heat sources is less than 40 F unless an Engineer approved cold weather paving plan is in effect.

The cold weather paving plan should include at minimum: changes to mix design, operational and equipment changes, and any other changes due to the cold temperatures. Approval of a cold weather paving plan does not relieve the Contractor of responsibility for the quality of paving placed under the cold weather paving plan.

Do not pave the lower layer of asphalt unless the air temperature approximately 3 feet above grade, in shade, and away from artificial heat sources is at least 34 F and rising.

Do not pave the upper layer of asphalt unless the air temperature approximately 3 feet above grade, in shade, and away from artificial heat sources is at least 40 F and rising.

All material placed in violation of an approved cold weather paving plan or in violation of these specifications shall be removed at the Contractor's expense.

AIR TEMP	UPPER LAYER	LOWER LAYER
Colder than 32 F	No paving allowed	No paving allowed
34 – 40 F	No paving allowed	Paving allowed with approved cold weather paving plan
Warmer than 40 F	Paving allowed	Paving allowed

5.3.06 ROLLING

Begin rolling when mixture will bear roller weight without excessive displacement. Two operational rollers must be on site at all times. In the event a roller becomes inoperable, the paving operation must cease immediately.

Compact mixture with hot hand tampers or vibrating plate compactors in areas inaccessible to rollers.

Perform finish rolling while mixture is still warm enough for removal of roller marks. Continue rolling until roller marks are eliminated and asphalt has attained the maximum density.

5.3.07 JOINTS

Pavement joint adhesive shall be applied to the vertical face of all curb adjacent to asphalt pavement immediately prior to surface paving operations. Follow all manufacturer's application instructions.

Joints between old and new pavements or between successive day's work shall be constructed and treated as to ensure thorough and continuous bond between the old and new mixtures.

- A. Transverse Joints.** Transverse joints shall be constructed by cutting the material back for its full depth so as to expose the full depth of the course. Where a header is used, the cutting may be omitted provided the joint conforms to the specified thickness. These joints shall be treated with pavement joint adhesive, per the manufacturer's instructions.
- B. Longitudinal Joint.** The longitudinal joint shall be made by overlapping the screed on the previously laid material for a width of not more than two inches (2"), and depositing a sufficient amount of asphaltic mixture so that the finished joint will be smooth and tight.

Longitudinal joints in the upper layer course shall at no time be placed immediately over similar joints in the lower layer course beneath. A minimum distance of twelve inches (12") shall be permitted between the location of the joints in the lower layer course and the location of similar joints in the upper layer course above. These joints shall be treated with pavement joint adhesive, per the manufacturer's specifications.

5.3.08 PRIME AND TACK COAT

If asphaltic upper layer course is applied to an existing street, the existing street or lower course surface shall be tack coated prior to upper layer paving.

Prior to placement of tack coat, the streets shall be thoroughly cleaned and broomed.

Tack coat shall be applied immediately prior to placement of asphaltic upper layer course and must break prior to paving upper layer. The rate of application shall be between 0.05 and 0.07 gallons per square yard after dilution, at a 50 percent or greater residual asphalt content. The Engineer reserves the right to take a field sample to determine compliance.

5.3.09 PAVEMENT MARKINGS

Pavement markings shall be applied per manufacturer's recommendations and only when the ambient or pavement temperature is 45°F and rising. If higher temperatures are required by the manufacturer for the specified paint, the manufacturer's recommendations shall govern.

Apply liquid marking and glass beads across the line at or exceeding the following:

LIQUID MARKING	PAVEMENT TYPE	THICKNESS	BEAD APPLICATION
		(mils)	(pounds per gallon)
Latex Paint	Parking Lots	16	10
Epoxy	SMA, Seal Coats, and Polymer Overlays	25	25
Epoxy	All others	20	22.5

Conform to ASTM D6628 color requirements. Ensure that the initial reflectivity, in millicandelas/lux/m², meets or exceeds the following:

MATERIAL	COLOR	INITIAL DAY RETROREFLECTIVITY
Latex Paint	White	275
	Yellow	185
Epoxy	White	275
	Yellow	185

5.3.10 PAVEMENT PATCHES AND REPAIRS

Saw cut the full depth of pavement, with minimum width of the patch being a full driving lane and minimum length being ten (10) feet. Saw cuts shall be performed so that asphalt joints do not fall in the driving lane. Asphalt patch thickness shall be the full depth of existing pavement plus one (1) inch; four (4) inch minimum. Engineer shall approve patching limits prior to saw cutting.

Pavement indentations in upper and lower courses may be heat repaired when allowed by Engineer.

5.4 FIELD QUALITY CONTROL AND TESTING

5.4.01 TESTING

Refer to WisDOT Specifications, Sections 460.2.8.3 – 460.3.3.1 except wherein modified or appended:

The Contractor shall allow access by the Engineer to observe Contractor sampling, testing, and material production. The Contractor shall allow access by the City's third-party Consultant Laboratory to sample production material at the plant.

A. Density Testing. Pavement densities shall be determined using the City of Fitchburg's third-party Consultant. The use of nuclear density testing equipment shall comply with WisDOT and the Department of Health and Safety pertaining to the use of the nuclear density equipment.

Density lots shall be calculated under the "nominal" system (up to seven (7) tests per 750 ton per layer) according the WisDOT Construction Materials Manual section 8-15-10.2, for all pavement lengths. All density test locations shall be randomly located throughout the lot.

It is encouraged to have the Contractor and City set up a common reference block, location determined at the City's discretion, for daily checks of nuclear gauges.

HMA Pavement Densities shall conform to the following:

HMA PAVEMENT MINIMUM DENSITIES		
MINIMUM %DENSITY REQUIREMENT	UPPER LAYER	LOWER LAYER
Roadways	93%	91%
Sports court/Shared-use Path	94%	92%

At the Engineer's discretion, if the average lot density falls below the minimum densities listed above, the material payment will be reduced based on the payment schedule below:

PAYMENT FACTORS	
PERCENT LOT DENSITY BELOW SPECIFIED MINIMUM	PAYMENT FACTOR (% of contract price)
From 0.0 to 0.5	98
From 0.6 – 1.5	95
From 1.6 to 3.0	85
Greater than 3.0	Remove & Replace at Contractor's expense

Assessed tonnage may include up to the total day's production. All available test data will be reviewed by the City and taken into consideration. The final assessed tonnage will be determined by the City at the City's sole discretion.

B. HMA Mixture Testing. The City shall use a third-party Consultant WisDOT Qualified Laboratory for verification of HMA samples. The testing may include any of the following:

- a. Gradation
- b. Asphalt Content (AASHTO T-164)
- c. Air Voids
- d. VMA

All test results will be made available to the Contractor.

Individual tests of the HMA pavement properties must conform to the requirements below, as compared to the submitted mix design:

HMA VERIFICATION PRODUCTION TESTING	
HMA PROPERTY	ALLOWABLE JMF TOLERANCE
#200 (0.075mm)	+/- 2.0%
%Va	+/- 1.3%
Asphalt Content (AASHTO T-164)	- 0.3%
Minimum % VMA	- 0.5%

At the Engineer's discretion, if the individual HMA property falls out of specification, the material payment will be reduced based on the payment schedule below.

HMA PAVEMENT REDUCTION OF PAYMENT SCHEDULE	
HMA PROPERTY	PAYMENT FACTOR (percent of contract price)
#200 (0.075mm)	95
Asphalt Content (AC) (AASHTO T-164)	90
%Va or %VMA	90

Assessed tonnage may include up to the total day's production. All available test data will be reviewed by the City and taken into consideration. The final assessed tonnage will be determined by the City at the City's sole discretion.

If multiple pay factors exist for the same tonnage, the assessed penalty will use the lowest of the payment factors. It is not intended to penalize the same material twice. The Contractor may dispute the City's quality verification test results by having their retained sample tested in a separate, third-party, WisDOT Qualified Laboratory. The test results from the City's third-party consultant laboratory and the Contactor's third-party laboratory will be averaged for pay adjustments.

END

SECTION 6 - STORM SEWER

6.1 GENERAL

6.1.01 RELATED DOCUMENTS

WisDOT Specifications, latest revision available at <https://wisconsindot.gov/Pages/doing-bus/eng-consultants/cnslt-rsrces/rdwy/stnds-spec.aspx>
City of Madison Standard Specifications for Public Works Construction, latest edition, available at: <http://www.cityofmadison.com/business/pw/specs.cfm>

ASTM C76-90 – Reinforced Concrete Culvert, Storm Drain, and Sewer Pipe

AASHTO M-198 – Joints for circular Concrete Sewer and Culvert Pipe Using Flexible Water tight Gaskets

6.2 MATERIALS

6.2.01 BEDDING AND COVER

Bedding and cover material shall be washed stone, all of which passes a 1-1/2" sieve.

6.2.02 GRANULAR BACKFILL

Granular Backfill for storm sewer shall be Grade 1 or Grade 2 as specified in Section 209 of the *WisDOT Specifications*. Use of screenings for Granular Backfill material is prohibited. No clay lumps and/or frozen material shall be present.

6.2.03 STORM SEWER PIPE

Reinforced concrete pipe shall be the only storm sewer material approved for use within public rights of way without specific written permission from the Department.

Reinforced concrete pipe shall meet the Standard Specifications for Reinforced Concrete Culvert, Storm Drain, and Sewer Pipe of the American Society for Testing Materials, Serial Designation C76 for circular pipe, Serial Designation C507 for elliptical pipe. Provide Class III unless indicated otherwise in the Specifications or on the Drawings.

Joints for circular pipe shall be tongue and groove meeting requirements of ASTM C443 and shall be installed with pre-manufactured gaskets.

6.2.04 APRON ENDWALLS

Reinforced concrete pipe apron endwalls shall be the only endwalls approved for use within public rights of way without specific written permission from the Department. Pipe Class shall match the adjacent pipe material unless otherwise approved by the Department. Joint ties shall be galvanized.

Cutoff walls shall be installed on apron endwalls located on the downstream end of pipes that are 24" or greater, or if the apron endwall is located within three inches of the permanent pool elevation.

6.2.05 PIPE GATES

Pipe gates for reinforced concrete pipe apron endwalls shall be provided in accordance with the *City of Madison Standard Specifications for Public Works Construction, latest edition*, for all pipes 15" in diameter and larger that are upstream or downstream of a closed system. Refer to the *City of Madison Standard Specifications for Public Works Construction, latest edition* for the specifications and standard detail drawings.

6.2.06 STORM SEWER STRUCTURES

Storm sewer structures less than or equal to 6-FT in diameter shall be precast reinforced concrete with cored, non-scored, smooth-formed openings. All precast storm sewer structures lids shall be tongue and groove. Storm sewer structures greater than 6-FT in diameter shall be field poured. In lieu of cored openings, structures may also have formed openings and/or be poured in place.

2' x 3' inlets shall conform to WisDOT Type 2x3-FT inlets. Four (4), Five (5), and six (6) foot diameter manholes shall conform to WisDOT Type 4-FT Diameter, 5-FT Diameter, and 6-FT Diameter manholes, respectively.

Manholes shall be reinforced concrete conforming to the Standard Specifications for Precast Reinforced Concrete Manhole Sections of ASTM C478.

The Contractor is responsible for notifying the City of inlets that may require false walls. False walls shall follow Standard Detail Drawing 6.04 and must be poured prior to placement of curb and gutter.

Adjusting rings shall be Ladtech® HDPE adjusting rings or approved equal. The first adjusting ring shall be sealed to the cone and the last adjusting ring shall be sealed to the casting using pre-compressed butyl rubber 3/8" x 3.5". An approved butyl sealant or a 3/8" round butyl sealant rope shall be placed in the annular space between the remaining rings. **Use of shims to adjust HDPE adjusting rings is prohibited.**

6.2.07 CASTINGS

Castings for various structure types shall be provided as follows. Contractor shall correctly orient the inlet grates relative to the direction of flow as directed by the Engineer. Inlet curb box heads shall read "DUMP NO WASTE DRAINS TO LAKE" per Standard Detail Drawing 6.02.

Structure Type	Neenah Casting Designator
Type 2x3-FT Inlet (Continuous Grade)	R-3067-7004-L (vane grate) Frame Model No.: 3067-2000
Type 2x3-FT Inlet (Low Point, single)	R-3067-7004-VB (two-way vane grate) Frame Model No.: 3067-2000
Type 2x3-FT Inlet (Low Point, twin)	R-3067-7004-L (vane grate) Frame Model No.: 3067-2000
Type 2x3-FT Inlet (Driveway)	R-3246-1 (grate as noted for conditions above) Frame Model No.: 3067-2000 Curb Plate Model No.: 3067-7014
Manhole	R-1550 (self seal, non-rock) Frame Model No.: 1050-2001-3

Non-rocking cast iron adjusting rings shall be as specified in SECTION 5 – PAVEMENTS.

6.3 EXECUTION

6.3.01 GENERAL

Before the start of construction, the Contractor shall verify existing storm sewers elevations with proposed plan elevations. All significant differences between existing storm sewer inverts and plan inverts (greater than 0.1") shall be reported to the Engineer.

Storm sewer shall be installed to an elevation tolerance of plus or minus 0.1 feet of the plan elevation or elevation provided on the grade sheet at any point along the main.

When a sewer crosses under a water main, provide a minimum of six inches (6") separation between the bottom of the water main and the top of the sewer. When a sewer crosses over a water main, provide a minimum of 18 inches separation between the top of the water main and the bottom of the storm sewer.

6.3.02 HANDLING OF MATERIALS

Handle materials with care to avoid damage. Do not dump or drop materials. Remove all damaged or flawed materials from the site.

Arrange for suitable sites for material storage.

6.3.03 LAYING OF PIPE

The trench shall be excavated to an elevation at least six inches (6") below the elevation established for the bottom of the pipe. This depth shall be backfilled with bedding material. Bedding and cover material shall be used for the full cross section of the excavated trench to the springline of the pipe being installed. Granular material shall be provided from the springline of the pipe to the proposed pavement subgrade.

Compaction of Granular Backfill material shall meet 95% Modified Proctor, the standard specification of ASTM D-1557, within three vertical feet (3') of the pavement subgrade. Compaction of Granular Backfill material shall meet 90% Modified Proctor, the standard specification of ASTM D-1557, in the cross-sectional area of the trench between the springline of the pipe and the plane three vertical feet (3') from the proposed pavement subgrade.

Not more than 200 feet of trench shall be opened at any one time. Not more than 100 feet of trench may be opened in advance of the completed pipe laying operations; and not more than one street crossing may be obstructed by the same trench at any one time.

Lay pipe uniformly to line and grade so that the finished sewer presents a uniform bore. Noticeable variations from true alignment and grade will be sufficient cause for rejection of the work.

Commence at the lowest point and proceed to the upper end. Lay pipe with bell-end pointing up-grade.

All storm sewer pipe must extend through the entire structure wall plus two inches (2") beyond.

When work has stopped for any reason, securely plug the end of the pipe.

Pipe jointing: Assemble joints in accordance with the pipe manufacturer's instructions.

Concrete pipe pick holes shall be tar sealed with a formed concrete plug or approved alternative.

6.3.04 BEDDING AND COVER

Provide a minimum of six inches (6") of bedding material under the pipe barrel and four inches (4") under the bell. Spade or shovel-slice the material so that it fills and supports the haunch area and encases the pipe. If excavation is carried deeper than six inches (6") below the pipe barrel, backfill the excess depth with bedding material.

After the pipe has been laid and jointed, place cover material by hand or equally careful means to the springline of the pipe. Compact cover material using tamping bars and/or mechanical tampers.

See Standard Detail Drawing 6.01 Storm Sewer Trench.

6.3.05 APRON ENDWALLS

Joint ties shall be installed at the last upstream and downstream two (2) joints on any pipe run ending in an apron endwall constructed with reinforced concrete pipe or horizontal elliptical reinforced concrete pipe of any size. Joint ties shall extend a maximum of two inches into the pipe. Riprap, underlined with geotextile fabric, shall be provided at the ends of the apron endwall as indicated on the plans or as directed by the Engineer. Placement shall be in accordance with Section 606 of the WisDOT Specifications. Geotextile fabric shall extend a minimum of two feet (2') under the apron endwall. See Standard Detail Drawing 6.06 Rip Rap and Endwall Installation.

Pick holes shall be sealed with concrete on the inside and the outside of the structure prior to backfilling.

6.3.06 PIPE GATES

Pipe gates for reinforced concrete apron endwalls shall be installed in accordance with the *City of Madison Standard Specifications for Public Works Construction, latest edition*.

6.3.07 STORM SEWER STRUCTURES

Storm sewer structures shall have a minimum of three inches (3") and a maximum of nine inches (9") of adjusting rings. Adjusting rings shall be installed per manufacturer's specifications and as herein specified. Prior to installation of adjusting rings, clean top of concrete structure of debris. Create a flat sealable surface using non-shrink mortar (4,000 psi) if the top of the concrete structure is too badly chipped to install the rings correctly. For storm sewer manhole structures install pre-compressed butyl rubber 3/8" x 3.5" between structure and first ring where the flat area of the ring will be in contact with the structure for the entire 360 degrees, one (1) 1/4" bead of sealant or 3/8" round butyl sealant rope on the entire 360 degrees of each rings male lip, and install pre-compressed butyl rubber 3/8" x 3.5" on top of the upper ring in a location so that it contacts the cover frame the full 360 degrees. Make sure all loose rust is removed from the casting before it is placed on the adjusting rings.

Storm sewer 2'x3' inlets, install pre-compressed butyl rubber 3/8" x 3.5" between structure and first ring and the top ring and the casting. Wrap outside of the adjusting rings on inlets with minimum four (4) ounce non-woven filter fabric. Lap filter fabric over inlet structure and casting by four inches (4") and itself by one foot (1'). Fasten filter fabric in place during

backfill operations. All adjustment for matching road grade shall be made by utilizing a molded and indexed slope ring. **Use of mortar or shims, or modifying adjusting rings to match road grades is prohibited.** A false wall must be poured if a horizontal adjustment is necessary, see Standard Detail Drawing 6.04 Inlet False Wall.

Storm sewer manhole rims may need adjustment from the plan elevation to meet field conditions. The cost of this work shall be incidental to the contract.

Poured concrete collars shall be vibrated and trowel finished. Collar shall be eight inch by eight inch (8"x8") on the exterior and extend around the entire pipe on both sides. The inside and outside of the collars shall be completed at the same time. Concrete collars shall cure for 24 hours and be inspected and approved by the Engineer prior to backfilling. All storm sewer structures shall have a field poured bench with a positive flow channel and bench. Concrete shall be per SECTION 4.2.01 – CONCRETE.

Pick holes shall be sealed with concrete on the inside and the outside of the structure prior to backfilling.

6.3.08 CASTINGS

Inlet castings shall be set to final grade with adjusting rings per SECTION 6.3.08 – STORM SEWER STRUCTURES prior to and separate from pouring the curb and gutter. Inlet castings shall be set with an eight inch (8") flow line depression from the top of curb. Concrete shall be poured behind the inlet casting to cover the bolt holes.

Manhole castings in roadways temporarily receiving lower course only, shall be set to binder grade. Manhole castings shall be set one-quarter inch (1/4") below final grade in all other areas unless otherwise directed by Engineer. "Scab" and monolithic ramping is prohibited.

Manhole castings set to binder grade, shall be brought to one-quarter inch (1/4") below surface grade immediately prior to placement of surface coarse, with non-rocking cast iron adjustment rings per SECTION 5.2.06 – ADJUSTING RINGS .

6.3.09 EXISTING STORM SEWER CONNECTIONS

All storm sewer connections to existing structures shall be made by using a coring machine with a poured concrete collar. The inside and outside of the poured concrete collar shall be completed at the same time. Concrete collar shall be vibrated and trowel finished. Poured concrete collars shall cure for 24 hours and be inspected and approved by the Engineer prior to backfilling. For connections, the Contractor shall have the option of using an approved watertight adaptor for the joint.

A poured concrete collar may be required at the junction of a new RCP pipe to an existing RCP pipe when identified on the plans or directed by Engineer. The junction shall be clean cut with no gap. Concrete collar shall have a minimum width extending one foot (1') in either direction of the joint and a minimum thickness around the pipe of eight inches (8"). Concrete collar shall be vibrated and trowel finished. Poured concrete collars shall cure for 24 hours and be inspected and approved by the Engineer prior to backfilling.

6.3.10 ABANDONMENT

A. Structures. The casting, all adjusting rings, and the top three feet (3') of the structure shall be removed. Castings are the property of the City. A hole shall be cut into the bottom of the structure to accommodate drainage through the structure. All openings within the structure shall be plugged with concrete. The entire structure shall be filled

in with granular material or cellular concrete. All disturbed areas shall be backfilled with the required backfill material.

- B. Pipe.** The apron endwall shall be removed. The pipe end shall be plugged with concrete.

6.3.11 DEWATERING

If conditions warrant, Contractor shall furnish and install well point systems or deep wells. Spacing and depth of well points or deep wells shall be adequate to lower the ground water table below the trench bottom. No extra payment will be made for dewatering of the trench whether accomplished by the use of sumps and pumps, well point systems or deep wells.

Contractor shall take all necessary precautions during the dewatering operation to protect adjacent structures against subsidence, flooding or other damage.

In areas where continuous operation of dewatering pumps is necessary, Contractor shall avoid noise disturbance to nearby residences to the greatest extent possible by using electric driven pumps, intake and exhaust silencers or housing to minimize noise.

Upon completion of the dewatering project, all dewatering wells shall be permanently abandoned. If dewatering wells are less than 25 feet deep they shall be permanently abandoned by removing the well casing and screens and filling the borehole with bentonite. If dewatering wells are 25 feet deep or greater, they shall be abandoned per NR 812.26.

6.3.12 FROST CLEARANCES

Storm sewers or culverts, which cross an active sewer, water main or lateral shall have a minimum clear vertical clearance of three feet (3'). Crossings with lesser vertical clearance shall be protected from frost damage by placement of two sheets (4'x8') of two-inch thick R-10, 25 psi, extruded polystyrene board insulation (four inches (4") total) staggered as directed by the Engineer.

6.4 FIELD QUALITY CONTROL AND TESTING

6.4.01 TELEVISIONING

All storm sewers, pipes and structures, shall be televised.

Closed circuit television shall be utilized for inspecting the interior of all completed sections of the mains. Televisioning shall take place after all utilities are installed, backfilled and compacted, all storm sewer has been cleaned, all road undercuts are complete, and prior to placement of any hard surface. Flash drive recordings of these inspections and written and pdf logs of same shall be submitted to and reviewed by the Engineer five business days prior to the placement of any hard surface. Flash drive recordings and written and pdf logs submitted to the Engineer shall exclusively be for storm sewer, or flash drive recordings and written and pdf logs for sanitary sewer shall be submitted separately. Inspection records shall be of suitable format, and shall include, but not necessarily be limited to, the following data:

Project Title, Owner Name
Date of Inspection, Type of Pipe and Size
Weather
Names of Inspectors and Technicians
Location of Line

Manhole Numbers, Section Length
Direction of Inspection and Measurements
Location, size, and direction of all laterals, including laterals extending from manholes
General Condition of Line
Deflections (vertical and horizontal)
Joint Conditions
Points of Infiltration, Locations of Obstructions

The television camera used shall be specifically designed and constructed for sewer inspection and shall take picture in color. Black and white imagery shall not be accepted. Lighting for the camera shall be operative in 100 percent humidity conditions. The camera shall have a minimum of 720x480 resolution. Picture quality and definition shall be to the complete satisfaction of the Owner. The improvements shall not be eligible for acceptance prior to Contractor's submission of televising records which are deemed satisfactory by the Owner.

The Contractor shall, prior to televising, deposit into the new sewer mains and services a minimum amount of water as directed by the Engineer to allow for indication of sags in the pipe.

Flash drive records shall be made of all sections of the new sewer main. The video shall be made continuously as the camera is pulled or driven through the line and shall include a panorama view of each manhole/inlet, each connection to the manhole/inlet, and each defect as well as confirmation that a plug has been installed in each pick hole. Each recording shall be in flash drive format and shall be numbered and dated. A list shall be provided on the container for each flash drive indicating the flash drive number, project name and sections of sewer included. All recordings shall be made on new flash drives and the flash drives shall become the property of the Owner. The Contractor shall be responsible for supplying all safety equipment necessary to complete the work in compliance with applicable OSHA and DCOM standards.

END

SECTION 7 - WATER MAINS, HYDRANTS, AND SERVICE LATERALS

7.1 GENERAL

7.1.01 RELATED DOCUMENTS

WUCA Specifications, latest edition

American Water Works Association Standards (AWWA), latest edition

WisDOT Specifications, latest revision available at
<http://roadwaystandards.dot.wi.gov/standards/stnds-spec/index.htm>

7.1.02 DESCRIPTION OF WORK

This section includes requirements for the provision and installation of water mains, fire hydrants, water services, and related fittings.

7.2 MATERIALS

7.2.01 BEDDING AND COVER

Bedding and cover material for water main, valves, hydrants, hydrant leads, water services, and related fittings, shall be approved bedding sand with 100% of material passing a 3/8" sieve. *No native material from trench shall be used for bedding or cover material.* Unwashed bank run sand and crushed bank run gravel will be considered generally acceptable cover material.

7.2.02 GRANULAR BACKFILL

Granular Backfill for water main shall be Grade 1 or Grade 2 as specified in Section 209 of the WisDOT Specifications. Use of screenings for Granular Backfill material is prohibited. No clay lumps and/or frozen material shall be present.

7.2.03 BACKFILL MATERIAL

When the type of backfill material is not specified, excavated backfill material may be used provided, that such material consists of loam clay, sand, gravel, or other materials, which, in the opinion of the Engineer, are suitable for backfilling. All backfill materials shall be free from cinders, ashes, refuse, organic matter, boulders, rocks or stone, frozen lumps or other such deleterious, unsuitable material.

7.2.04 WATER MAIN PIPE, FITTINGS, AND ACCESSORIES

All water main pipe, fittings and specials shall be ductile iron conforming to AWWA C151 and shall be manufactured in the United States of America (U.S.) and labeled as such. All water main pipe and fitting manufacturers shall be U.S. companies with their headquarters located in the U.S. Use of foreign materials is prohibited. Thickness class and joint style shall be as specified below for type of installation. Use of polyvinyl chloride water pipe or other composite materials is not allowed.

- A. Pipe.** All buried water main pipe shall be push-on or mechanical joint and minimum special thickness Class 52 with a minimum rated working pressure of 350 psi. Pipe wall thickness shall also meet the requirements of AWWA C150 for buried piping with depth and cover as shown in Figure 1 for *laying condition Type 5 with the addition of one foot (1') of cover over top of pipe*. The words "Ductile Iron" or "DI" along with the weight and thickness class of pipe shall be plainly marked on the exterior of each water main pipe.

All pipe shall be furnished with cable bond conductor or electrobond conductivity strips. Thermite welded straps are allowed provided weld points are thoroughly coated with bitumastic material.

Inner surfaces of all ductile iron piping shall be cement mortar lined and coated per AWWA C104. All buried ductile iron piping shall be coated on the outside per AWWA C104.

All exposed water main, interior piping, and piping in pits or manholes shall be flanged joint and minimum special thickness Class 53 with a minimum rated working pressure of 350 psi. Pipe wall thickness shall also meet the requirements of AWWA C115 for flanged joint.

Exposed interior piping shall be furnished with outside surfaces prepared in accordance with near white grade NAPF 500-03, removing all dirt, rust scale, and foreign materials. Cleaned surfaces shall be shop primed. Shop priming shall be with one coat of Tnemec 69-1255 Hi-Build Epoxoline primer, or equal, applied to a minimum of 5.0mils dry thickness. Primer used shall be compatible with proposed finish coats; Contractor to verify. All piping, supports, and appurtenances shall be furnished shop primed, clean, and ready to accept finish painting by Contractor, with a minimal amount of surface preparation.

In cases where corporation stops are to be tapped into mains, pipe wall thickness shall be furnished as specified in AWWA C151. Pipe saddles may be furnished in lieu of pipe thickness as approved by Utility.

- B. Gaskets.** Mechanical joints or push-on joints shall utilize vulcanized synthetic rubber gaskets and shall conform to AWWA C111. Bolts on the exterior joints shall be high-strength low-alloy steel (Corten or equal) conforming to AWWA C111. Certificate to the effect shall be provided.

All valves, hydrants, and fittings require armor tipped gaskets at mechanical joints. Lead tipped conductivity gaskets and bronze wedges are prohibited.

Use restrained joint locking gaskets when electing to or are otherwise required to meet thrust-restraint requirements. Restrained-joint locking gaskets must be **made by the same manufacturer as the water main pipe** and certified as compliant for use with the furnished pipe material by the pipe manufacturer.

If contaminated soils are encountered gaskets shall be as recommended by Engineer.

- C. Polyethylene Encasement.** All buried ductile iron water main piping and fittings shall be polyethylene encased in accordance with AWWA C105. Polyethylene encasement shall be a minimum 8mil thickness and installed in accordance with AWWA C105.

- D. Restraints.** Megalug glands shall be Ebaa Iron Inc. Series 1100, or approved equal.

Threaded rods for restraint shall be 3/4-inch 304 stainless steel threaded rods with stainless steel nuts and washers.

- E. Fittings.** All water main fittings shall be ductile iron conforming to AWWA C153 or AWWA C110.

Slip Joint fittings are prohibited.

Inner surfaces of all ductile iron pipe fittings shall be cement mortar lined and coated per AWWA C104. All buried ductile iron pipe fittings shall be coated on the outside per AWWA C104.

Water main plugs; in the absence of a flushing hydrant, Contractor shall furnish and install mechanical joint caps with a ¾" corporation stop in all plugged dead ends. Care shall be taken in placing concrete for thrust blocks to protect the corporation and retain operability. All ends shall be marked with a 10-foot, 4"x4" placed at the invert and painted blue.

Tapping sleeves shall be Smith Blair 622, epoxy coated carbon steel sleeve with mechanical joint outlet and stainless steel bolts, or approved equal.

- F. Nuts and Bolts.** All Nuts and Bolts shall comply with AWWA C111/A21.11. – Latest revision. Stainless steel bolts shall be used for connection of valves and hydrants.

Nuts and bolts for water main and fittings, excluding valves and hydrants, shall be supplied with baked-on ceramic fluorocarbon resin.

Ensure that bolts are sufficient length such that a minimum of 1/2-inch of threads are exposed beyond the end of the nut when tightened.

7.2.05 VALVES AND VALVE BOXES

Resilient Wedge Gate Valves: All valves 16" or smaller shall be resilient seat gate valves meeting the requirements of AWWA C509. Gate valves shall have ductile iron body, resilient wedge, non-rising stem and O-ring packing box, and rated for 250-psi working pressure. All water main gate valves shall have mechanical joint ends unless otherwise specified. Valves shall be American Flow Control resilient wedge gate valves or approved equal. Operators on water main valves shall be 2-inch square nut. Stainless steel bolts shall be used for connection of valve to water main pipe.

Buried valves shall be epoxy coated in accordance with AWWA C550.

Valve box stabilizer shall be Adaptor, Inc., or approved equal. Determination of specific model shall be as recommended by the manufacturer.

Valve boxes shall be Tyler Model No. 6860DD, or equal, with No. 6 base, three (3) piece screw type bow, 5-1/4 inch shaft and stay-put cover marked "WATER". Valve boxes shall be manufactured in the United States of America and labeled as such. Use of foreign materials is prohibited.

A minimum of 10 gauge coated **solid** copper wire or equivalent shall be used to provide continuity across valve.

Rubber-Seated Butterfly Valves: All valves 20" or larger shall be rubber-seated butterfly valves meeting the requirements of AWWA C504. Joint style shall be as specified for piping installation. Butterfly valves shall be open left, Mueller 3211-20 or approved equal.

7.2.06 FIRE HYDRANTS

All fire hydrants, private and public, shall conform to AWWA C502 with 5-1/4 inch main valve opening, 6-inch mechanical joint inlet, two (2) 2-1/2 inch National Standard hose connections, one 4-1/2 inch National Standard pumper connection, 1-1/2 inch pentagon operating nut and caps, open left. No weather shield shall be provided on top operating nut. Hydrant shall have bronze seat ring and seat insert, plastic drain tube, and ductile iron stand pipe, nozzle section, bottom and cross arm. Hydrant shall be Waterous WB-67, seven foot (7') bury, with breakaway flange and painted red. All areas of hydrant with paint defects shall be repainted with Waterous Touch-up Kit or approved equal. Stainless steel bolts shall be used for connection of hydrant to water main pipe.

Fire hydrant markers shall be 48-inch, red, *Slimline FH* fire hydrant marker manufactured by Flexstake, Inc., Model No. SFH-4.

Fire hydrant leads shall be Class 52 ductile iron and all joints in the lead shall be mechanical joints with Megalug glands, rodding, or an approved locking joint conforming to the requirements in 7.2.04 WATER MAIN PIPE FITTINGS AND ACCESSORIES. All public fire hydrant leads shall be six inch (6") in diameter unless otherwise specified. All private mains between a municipal main and a private fire hydrant shall be eight inch (8") in diameter.

Fire hydrant auxiliary valves shall be gate valves conforming to the requirements in 7.2.05 VALVES AND VALVE BOXES.

A minimum of 10 gauge coated solid copper wire or equivalent shall be used to provide continuity across hydrant foot valve.

7.2.07 WATER SERVICES

Materials for water services four inches (4") and larger shall be as specified above in 7.2.04 WATER MAIN PIPE FITTINGS AND ACCESSORIES and in 7.2.05 VALVES AND VALVE BOXES.

Water service piping for services smaller than four inches (4") shall be Type K soft copper conforming ASTM B88. Use of PVC water service piping or other composite materials is not allowed. Corporations, curb stop valves, and curb boxes shall be as follows:

- A. 3/4-inch and 1-inch services.** Corporations shall be Mueller H-15008N, compression fitting connection. Curb stop valves shall be Mueller II Oriseal H-15209N, compression fitting connection.
- B. 1-1/2-inch and 2-inch services.** Saddles shall be a Mueller double-strap bronze service saddles or approved equal. Corporations shall be Mueller H-15013N, compression fitting connection. Curb stop valves shall be Mueller II Oriseal H-15209N, compression fitting connection.
- C. Curb Boxes.** Curb boxes shall be Mueller H-10385 or H-10386, as applicable, arch style, complete with lid. For 3/4-inch and 1-inch services, a 4-foot stationary rod, Mueller 84154 or 580565, is required. Lids shall be marked "WATER" and set to final grade.
- D. Connection.** Union shall be Mueller H-15403N, three-piece compression union for splicing copper. Splicing will only be allowed if service run is longer than available lengths of service material.

7.2.08 ABANDONMENT

Water Mains ends to be abandoned and to be left in service shall be sealed with mechanical joint plugs and caps. Mechanical joint plugs and caps shall be ductile iron conforming to AWWA C153 or AWWA C110.

Rough brass plugs shall be installed with Mueller H-15451N 110 Compression Fitting, at the ends of all copper water services to be abandoned.

7.2.09 INSULATION

Insulate with two sheets (4'x8') of two-inch (2") thick R-10, 25 psi, extruded polystyrene board insulation (four inches (4") total).

7.3 EXECUTION

7.3.01 GENERAL

Before the start of construction, the Contractor shall verify existing water main location and elevations with proposed plans. All significant differences between existing water main locations (greater than one foot (1')) and elevations (greater than six inches (6")) shall be reported to the Engineer.

Water main shall be installed to an elevation tolerance of plus or minus 0.1 feet of the plan elevation or elevation provided on the grade sheet at any point along the main.

When a sewer crosses under a water main, provide a minimum of six inches (6") of separation between the bottom of the water main and the top of the sewer. When a sewer crosses over a water main, provide a minimum of 18 inches separation between the top of the water main and the bottom of the sewer.

7.3.02 HANDLING OF MATERIALS

Handle materials with care to avoid damage. Do not dump or drop materials. Remove all damaged or flawed materials from the site.

7.3.03 TRENCH

The width of trench below the outside top of the pipe shall be as shown in the following table for the sizes listed. A minimum clearance of eight inches between the outside of the pipe barrel and the trench wall at the pipe spring line shall be maintained. If sheeting is used, the trench width shall be measured as the clear distance between inside faces of the sheeting.

MAXIMUM WIDTH OF TRENCH BELOW TOP OF PIPE

Internal Pipe Diameter (inches)	Trench Width (inches)
4 -6	30
8 – 12	36
16	39
20 or larger	42

Not more than 200 feet of trench shall be opened at any one time. Not more than 100 feet of trench may be opened in advance of the completed pipe laying operations; and not more than one street crossing may be obstructed by the same trench at any one time.

7.3.04 BEDDING AND COVER

Bedding and cover material shall be provided for all water main, valves, hydrants, hydrant leads, water services, and related fittings.

Bedding shall be a minimum of six inches (6") thick. Bedding shall extend to the full width of the trench. Contractor shall perform all necessary excavation and shall furnish all required material to provide this bedding. If excavation is carried deeper than the required bedding thickness, the excess depth shall be backfilled with bedding material. Bedding material shall be compacted using tamping bars and/or mechanical tampers.

All trenches shall be backfilled to one foot (1') above the top of the pipe with approved cover material. Cover material shall be deposited in the trench for its full width on each side of the pipe, fittings and appurtenances simultaneously and shall be compacted using hand tamping bars and/or mechanical tampers.

7.3.05 GRANULAR BACKFILL

Granular backfill shall extend from one foot (1') above the pipe to the proposed pavement or hard surface subgrade and within the surfaces zone of influence. Compaction of granular backfill material shall meet 95% Modified Proctor, the standard specification of ASTM D-1557, within three feet (3') of the pavement or hard surface subgrade. Compaction of granular backfill material shall meet 90% Modified Proctor, the standard specification of ASTM D-1557, in the cross-sectional area of the trench between one foot (1') above the pipe and the plane three vertical feet (3') from the proposed pavement or hard surface subgrade.

7.3.06 BACKFILL

When the type of backfill material is not otherwise specified, excavated material may be used for backfill material as long as it meets the requirements of 7.2.03 BACKFILL MATERIAL. Compaction of backfill material shall meet 90 % Modified Proctor, the standard specification of ASTM D-1557.

7.3.07 WATER MAIN PIPE, FITTINGS, AND ACCESSORIES

All pipe and fittings shall be installed to a minimum depth of cover of six and one half feet (6.5'). Installations, which cannot meet this requirement, will require insulation as required and approved by the Engineer.

All ductile iron pipe and fittings shall be encased in polyethylene in accordance with manufacturer's instructions. Any rips or punctures shall be covered with polyethylene and sealed.

Thrust restraint shall be designed and provided in accordance with AWWA M41, Manual of Water Supply Practices. Concrete thrust blocking is also required for hydrants, tees, and bends. Thrust blocking for mains 12-inches and larger as well as areas with high pressure and/or flows shall be poured in place. Concrete thrust blocks shall be placed to permit full access to pipe and accessories.

Megalug glands or steel rodding shall be used at all horizontal and vertical bends, tees, reducers, hydrant leads, valves, and any joint fifteen feet (15') or less from a horizontal or vertical bend, reducer, cap/plug, or branch section of tee. Restrained-Joint locking gaskets may be used at pipe joints.

When work is stopped for any reason, securely plug the end of the pipe with a watertight plug or cap.

7.3.08 VALVES AND VALVE BOXES

Valves shall be set on solid bearing ground. Jump valves with coated **solid** copper wire or equivalent to adjacent pipes as necessary to provide full continuity across valve. Install valve box stabilizers on all gate valves four inches (4") and larger. Set valve box on valve box stabilizer, plumb over valve. Valve boxes shall be set to binder grade unless otherwise directed by Engineer. Valve boxes must be straight and centered over valve operating nut. Valve wrench shall not touch sides of box when operating.

An operator nut extension shall be installed by the Contractor when the vertical distance between the top of the nut to the finished pavement surface exceeds eight feet (8'). Operator nut extensions will be supplied by the City at no cost to the Contractor.

7.3.09 FIRE HYDRANTS

The fire hydrant shall be connected to the auxiliary valve with a two foot (2') length of pipe. All joints on the fire hydrant leads, including valve joints, shall be made using Megalug glands, rodding, or an approved locking joint. Reaction backing shall be provided for all hydrants. About one-half cubic yard of 1-1/2" clear (washed) stone shall be placed from the bottom of the trench around the hydrant elbow and up the hydrant barrel. The clear stone shall be covered with 8mil plastic to prevent the mixing of fines from the backfill.

Thrust restraint shall be designed and provided in accordance with AWWA M41, Manual of Water Supply Practices. All thrust blocking for hydrants shall be concrete. Concrete thrust blocks shall be placed to permit full access to pipe, drain holes, and accessories.

Contractor shall furnish all necessary fittings in the fire hydrant lead in order to install the fire hydrant in a plumb condition at locations shown on the drawings and at the specified depth of bury. The pumper nozzle of all fire hydrants shall be installed with the nozzle pointing toward the street or other accessible hard surface with center at 24" above the ground. Fire hydrant auxiliary valves shall be installed behind the curb, unless otherwise directed by Engineer. Engineer reserves the right to alter the location of fire hydrants from that shown on the drawings.

Hydrants and hydrant auxiliary valves shall be jumped with **solid** copper wire or equivalent to adjacent pipes as necessary to provide full continuity across hydrant and valve.

Hydrant leads with less than three feet (3') of vertical clearance at a storm sewer or culvert crossing, or with less than six and one-half feet (6.5') of cover from surface elevation, shall be protected from frost damage by installing two (2) 4'x8' sheets of two inch (2") thick insulation board (four inch (4") total thickness) within six inches (6") of the lead on even cover material. Joints shall be staggered and tapped as directed by Engineer.

The base of the hydrant may not exceed a depth of nine feet (9') below finish grade.

Ensure that the hydrant is set so the bury-line is not below finish grade and not more than two inches (2") above finish grade.

No more than one (1) hydrant extension will be permitted per hydrant installation. Notify the Engineer at least two (2) working days prior to installing an extension. Engineer must be present during extension installation.

7.3.10 WATER SERVICES

All services shall be installed to a minimum depth of cover of six and one-half feet (6.5'). Installations, which cannot meet this requirement, will require insulation as required and approved by Engineer.

Laterals shall be extended 10 feet beyond the right-of-way or easement line, whichever is further from the roadway centerline.

Water services less than four inches (4") in diameter shall include a corporation stop, copper tubing, curb stop, curb box, couplings, and all other appurtenances necessary for complete installation. All corporations shall be pressure tapped. Corporations shall not be tapped closer than two feet from each other. Curb boxes shall be placed on a minimum 8"x12"x2" thick solid concrete blocks lying on solid bearing ground. Curb stop boxes shall be adjusted to grade by using the extension within the box. No additional extensions are allowed, unless directed by Engineer.

Water services four inches (4") and larger shall be installed per section 7.3.07 WATER MAIN PIPE FITTINGS AND ACCESSORIES. Water service valves for services four inches (4") and larger shall be installed per 7.3.08 VALVES AND VALVE BOXES with the exception that valve box shall be set to final grade if not located within the pavement. Water service curb boxes and valve boxes shall be marked with a 2"x4" wood post, placed vertically two feet (2') under the surface and extending two feet (2') above ground. All curb box/valve box markers shall be painted blue.

All water service stubs shall be marked with a 4"x4" wood post, placed vertically at their invert and extending two feet (2') above ground. All water service markers shall be painted blue.

Water services two inches (2") or less in diameter shall be installed more than five feet (5') from a sewer (clear distance) and/or a minimum of 12 inches above sewer (clear distance). Water services larger than two inches (2") in diameter shall be installed a minimum of eight feet (8') from a sewer (center of pipe to center of pipe).

Water laterals with less than three feet (3') of vertical clearance at a storm sewer or culvert crossing, or with less than six and one-half feet (6.5') of cover from surface elevation, shall be protected from frost damage by installing two (2) 4'x8' sheets of two inch (2") thick insulation board (four inch (4") total thickness) within six inches (6") of the lateral on even cover material. Joints shall be staggered and taped as directed by Engineer.

7.3.11 ABANDONMENT

Water mains and water service laterals shall be abandoned in accordance with WUCA Specifications accept as herein modified.

When abandoning existing water main, mechanical joint plugs shall be installed into existing fittings and mechanical joint caps shall be installed over existing pipe ends of water main to be abandoned and water main that will remain in service. Plugs, caps, and all joints within fifteen feet (15') of the cap or plug of main to remain in service shall have Megalug glands, rodding, or an approved restrained-joint locking gasket. The ends of existing pipe and any disturbed fittings to remain in service shall be thrust blocked. When valves are to

be abandoned, the entire valve box shall be removed. All disturbed areas shall be backfilled with the required backfill material.

All water service laterals, to be abandoned, shall be abandoned at the corporation unless otherwise directed by the Engineer. The copper pipe shall be cut two feet (2') from the corporation and rough brass plugs shall be installed with Mueller H-15451N 110 Compression Fitting, at the ends of all copper water services to be abandoned. The entire curb/valve box shall be removed and all disturbed areas shall be backfilled with the required backfill material.

7.3.12 INSULATION

Water main and water services with less than three feet (3') of vertical clearance at a storm sewer or culvert crossing, or with less than six and one-half feet (6.5') of cover from surface elevation, shall be protected from frost damage by installing two (2) 4'x8' sheets of two inch (2") thick insulation board (four inch (4") total thickness) within six inches (6") of the main on even cover material. Joints shall be staggered and taped as directed by Engineer. A minimum of six inches (6") of cover material shall be installed below and above the insulation.

7.4 FIELD QUALITY CONTROL AND TESTING

7.4.01 DISINFECTION AND STERILIZATION

Contractor shall disinfect and sterilize all new and old mains where it is necessary to cut into them. The disinfection shall be done in accordance with AWWA C651. All materials and equipment needed for disinfection of mains shall be furnished by Contractor. Heavily chlorinated water, used for the purpose of disinfecting the mains, shall not remain in the water mains for more than five (5) days. Contractor shall be responsible for flushing of mains. Contractor shall fill out a flushing permit 24 hours prior to any flushing. Flushing procedures shall be reviewed and approved by the Engineer prior to flushing. No flushing shall be permitted on Fridays. Heavy chlorinated water shall be flushed down sanitary sewer unless directed otherwise by Utility. All other water shall be flushed through a diffuser or dechlorinated. Contractor shall be required to obtain all safe water samples for entire system being installed prior to hydrostatic and leakage test. Contractor shall obtain water sample bottles from the Utility and deliver them to the State Lab of Hygiene. All testing shall be under the direction of the Engineer. The Contractor shall be responsible for any necessary water main repairs, permits for flushing, flushing and re-sampling until safe samples are received. The Utility will open the tested main to the system.

Water mains shall be flushed prior to installation of copper water services. Two (2) sets of safe water samples shall be obtained; one (1) set prior to installation of water services and a second set after installation of water services. Both sets of safe samples shall be obtained prior to hydrostatic and leakage test.

7.4.02 TESTING

A combined hydrostatic pressure and leakage test shall be performed on all pipe, fittings, services and joints in accordance with AWWA C600 after service laterals and storm sewer are installed, and prior to placement of base course. During performance of test, water main shall be pressurized to 150% of maximum operating pressure, 150 psi minimum. All air shall be removed from the mains prior to testing by flushing and, as necessary, by installing corporations at high points. Test shall meet requirements of AWWA C600 for a minimum of two (2) consecutive hours. Prior to conducting the combined pressure and leakage test, Contractor shall backfill the trench for its full depth. All bends, services and

special connections to the main shall be adequately blocked and tied prior to the test. Any damage caused to the water main, or its appurtenances during performance of these tests shall be corrected by Contractor at the Contractor's expense. Use of hydrants to pressure test mains shall be at Contractor's risk. If the bronze drainage tube in a hydrant is the cause of a failed leakage test, Contractor shall replace bronze drainage tube with a plastic drainage tube and retest at their expense.

Contractor shall keep a record of all tests performed. These records shall show the individual lengths of main tested and test results.

Where connections are made to existing mains, it shall be the responsibility of Contractor to provide the necessary hydrostatic test on all new mains installed. This may require, but is not limited to, the installation of temporary valves to isolate the new system from the existing system. All materials, work and equipment necessary for this work shall be furnished by Contractor at the Contractor's expense.

Tapping sleeves shall be pressurized to 150psi for 10 minutes.

Continuity Tests: Contractor shall furnish all equipment, labor and miscellaneous items necessary to perform electrical continuity test on all new water main installed. Three (3) methods are acceptable for testing continuity. Method 1 tests shall be performed using an ohmmeter to assure that electrical continuity exists across all joints. Method 2 tests shall be performed using a reactivity tester. Method 3 tests shall be performed through the use of an energized underground utility locating device. Contractor shall make all necessary repairs to establish continuity across joints.

END

SECTION 8 - SANITARY SEWER MAINS AND LATERALS

8.1 GENERAL

8.1.01 RELATED DOCUMENTS

WUCA Specifications, latest edition

WisDOT Specifications, latest revision available at

<https://wisconsindot.gov/Pages/doing-bus/eng-consultants/cnslt-rsrcs/rdwy/stnds-spec.aspx>

8.1.02 DESCRIPTION OF WORK

This section includes requirements for the provision and installation of sanitary sewer mains, structures, and laterals.

8.2 MATERIALS

8.2.01 PIPE BEDDING AND COVER

All pipe shall be bedded and covered in approved 3/4 inch clear (washed) stone. *No native material from trench shall be used for bedding material.*

8.2.02 GRANULAR BACKFILL

Granular Backfill for sanitary sewer shall be Grade 1 or Grade 2 as specified in Section 209 of the WisDOT Specifications. Use of screenings for Granular Backfill material is prohibited. No clay lumps and/or frozen material shall be present.

8.2.03 BACKFILL MATERIAL

When the type of backfill material is not specified, excavated backfill material may be used provided that such material consists of loam clay, sand, gravel, or other materials which, in the opinion of the Engineer, are suitable for backfilling. All backfill materials shall be free from cinders, ashes, refuse, organic matter, boulders, rocks or stone, frozen lumps or other such deleterious, unsuitable material.

8.2.04 SANITARY SEWER PIPE AND FITTINGS

A. Fiberglass Sewer Pipe and Fittings. All sanitary sewer pipe 18" and larger shall be fiberglass reinforced polymer pipe manufactured in accordance with ASTM D3262. Minimum pipe stiffness shall be 46 psi. Joints shall meet the requirements of ASTM D4161. Joint Type shall be FWC Coupling w/ EPDM Gasket or double bell pressure coupling. Chemical resistance of pipe shall meet or exceed the requirements of ASTM D3262 Table 4 when tested in accordance with ASTM D3681. Contractor shall submit a Certification of Compliance with ASTM D3262 with submittal. Acceptable manufactures include Hobas Pipe USA, Flowtite, or approved equal.

B. Polyvinyl chloride gravity sewer pipe and fittings. All sanitary sewer pipe less than 18" shall be Polyvinyl (PVC) sewer pipe meeting the requirements ASTM D3034 for Type PSM Polyvinyl Chloride Sewer Pipe and Fittings. All PVC sewer pipe shall have maximum standard dimension ratio (SDR) of 26. Use of Multi Fittings is prohibited.

Joints in PVC sewer pipe and fittings shall be elastomeric. Fittings shall be of standard manufacture; injection molded, and shall have a maximum standard dimension ratio (SDR) of 26.

PVC pipe and fittings manufacturer shall have an experience record substantiating acceptable performance of the materials to be furnished.

- C. Ductile Iron Sewer Pipe and fittings.** Ductile iron pipe and fittings shall meet requirements of AWWA C151 and shall be manufactured in the United States of America and labeled as such. Use of foreign materials is prohibited. All buried sewer main pipe shall be push-on or mechanical joint conforming to AWWA C111, and minimum special thickness Class 52. Pipe wall thickness shall also meet the requirements of AWWA C150 for buried piping with depth and cover as shown on the drawings for laying condition five (5). All ductile iron pipe shall have AWWA C104 cement mortar lining. Fittings shall be furnished as necessary in gravity mains to make connections and to conform to the plan layout. Fittings shall be mechanical joint or push-on or flanged, conforming to AWWA C111.
- D. Special pipe and fittings.** Wye and Tee Branches. Wye or tee branches shall be built into the main for use in making service connections. The openings in the wyes or tees for sanitary service pipes shall be six inches (6") in diameter unless otherwise shown or specified. These openings, except in those that are to be used for extending laterals, shall be closed with airtight stoppers blocked to withstand air test pressures. Wyes shall be turned so that the branch is at an angle of 30 or 45 degrees with the horizontal. Branches shall be of the same material as the main for smaller diameter sewer. For larger diameter mains, special branch fittings shall be required and installed as specified.

When construction is within 50-feet of a potable water well, 200-feet of a municipal well, or otherwise requested by Engineer, pipe used shall comply with Wisconsin Department of Safety and Professional Services and Wisconsin Department of Natural Resources requirements.

To transfer from pipe specified under this section to pipe normally supplied, a transition pipe with suitable gasketed joints to mate the two (2) different pipes shall be supplied. No field construction transitions will be allowed unless specified by Engineer. Construction shall not proceed until proper transition pipe, as approved by Engineer, is supplied. Strong Back Ferncos may only be used on public mains and services when one or both of the pipe materials at a pipe transition are clay. All other ferncos are prohibited for any use.

Special fittings shall be as called for on the drawings. All reinforcing to be cut in construction of fittings shall be lapped and welded to develop full strength of the reinforcing wire prior to cutting. Wall thickness of fittings when pipe is cut or jointed shall be 50% greater than the normal wall thickness for that size of pipe. The inside of pipe at bends shall be formed to a radius of at least 1/3 the pipe diameter. The full cross sectional area of the pipe interior shall be maintained at all points. Fitting materials, construction, and curing shall be as specified for straight pipe.

8.2.05 SANITARY SEWER STRUCTURES

Precast sewer access structures shall be of reinforced concrete and shall conform to the requirements of the Specification for Precast Reinforced Concrete Sewer Access Structure Section, ASTM C478. Standard manholes shall be constructed with eccentric cone top section of 48-inch diameter barrel sections. For other diameters, the top section shall be eccentric cone if available, flat slab, or as otherwise called for.

All joints between manhole pipe sections and top shall be tongue and groove. In sanitary sewer manholes, joints shall be sealed with circular O-ring conforming to ASTM C-443 or bituminous jointing material equal to Ram-Nek or Mas-Stik meeting ASTM C-990.

Manhole connections for sanitary sewer main shall be made using flexible, watertight connections, A-Lok, KOR-N-SEAL or approved equal.

Internal chimney seals shall be Cretex Specialty Products or approved equal.

Adjusting rings shall be Ladtech® HDPE adjusting rings or approved equal. Pre-compressed butyl rubber shall be 3/8" x 3.5". Butyl sealant or 3/8" butyl sealant rope shall be approved by Ladtech.

8.2.06 CASTINGS

All sanitary sewer manhole castings shall meet the Standard Specifications for Gray Iron Castings, ASTM A48, Class 30. All castings unless otherwise specified, shall be Neenah Foundry R-1550, with Type "B" non-rocking, self-sealing sewer access structure lids with concealed pipe holes.

Non-rocking cast iron adjusting rings shall be as specified in SECTION 5 – PAVEMENTS.

8.2.07 SANITARY SEWER SERVICE LATERALS

Materials for sanitary sewer service laterals, within the right-of-way, shall conform to the requirements set forth in these specifications for sanitary sewer main.

ScotchMark Ball Markers, installed for locating purposes, shall be Product No. 1404-XR. Ball Markers shall be green in color.

Lateral connectors for existing non-PVC mains shall be Inserta Tee or approved equal.

All plugs and caps shall be manufactured to fit the pipe used and shall be watertight.

8.3 EXECUTION

8.3.01 GENERAL

Before the start of construction, the Contractor shall verify existing sanitary sewers elevations with proposed plan elevations. All significant differences between existing sanitary sewer inverts and plan inverts (greater than 0.1') shall be reported to the Engineer.

Sanitary sewer shall be installed to an elevation tolerance of plus or minus 0.1 feet of the plan elevation or elevation provided on the grade sheet at any point along the main.

When a sanitary sewer crosses under a water main, provide a minimum of six inches (6") of separation between the bottom of the water main and the top of the sanitary sewer. When a sanitary sewer crosses over a water main, provide a minimum of 18 inches separation between the top of the water main and the bottom of the sanitary sewer.

8.3.02 HANDLING OF MATERIALS

Handle materials with care to avoid damage. Do not dump or drop materials. Remove all damaged or flawed materials from the site.

8.3.03 TRENCH

The width of trench below the outside top of the pipe shall be as shown in the following table for the sizes listed. A minimum clearance of eight inches between the outside of the pipe barrel and the trench wall at the pipe spring line shall be maintained. If sheeting is used, the trench width shall be measured as the clear distance between inside faces of the sheeting.

MAXIMUM WIDTH OF TRENCH BELOW TOP OF PIPE

Internal Pipe Diameter (inches)	Trench Width (inches)
4 -6	30
8 – 12	36
15	39
18 or larger	42

Not more than 200 feet of trench shall be opened at any one time. Not more than 100 feet of trench may be opened in advance of the completed pipe laying operations; and not more than one street crossing may be obstructed by the same trench at any one time.

8.3.04 PIPE BEDDING AND COVER

Bedding and cover material shall be provided for pipe, fittings and structures.

Provide a minimum of six inches (6") of bedding material under the pipe and fittings, and six inches (6") of bedding material under the structures. Bedding shall extend to the full width of the trench. Contractor shall perform all necessary excavation and shall furnish all required material to provide this bedding. If excavation is carried deeper than the required bedding thickness, the excess depth shall be backfilled with bedding material.

All trenches shall be backfilled to one foot (1') above the top of the pipe with approved cover material. Cover material shall be deposited in the trench for its full width on each side of the pipe, fittings and appurtenances simultaneously and shall be compacted using hand tamping bars and/or mechanical tampers. Hand chuck cover material under full length of pipe.

8.3.05 GRANULAR BACKFILL

Granular Backfill shall extend from one-foot (1') above the pipe to the proposed pavement or hard surface subgrade and within the surfaces zone of influence. Compaction of Granular Backfill material shall meet 95% Modified Proctor, the standard specification of ASTM D-1557, within three feet (3') of the pavement or hard surface subgrade. Compaction of Granular Backfill material shall meet 90% Modified Proctor, the standard specification of ASTM D-1557, in the cross-sectional area of the trench between one-foot (1') above the pipe and the plane three vertical feet (3') from the proposed pavement or hard surface subgrade.

8.3.06 BACKFILL

When the type of backfill material is not otherwise specified, excavated material may be used for Backfill Material as long as it meets the requirements of 8.2.03 BACKFILL MATERIAL. Compaction of Backfill Material shall meet 90 % Modified Proctor, the standard specification of ASTM D-1557.

8.3.07 SANITARY SEWER PIPE AND FITTINGS

Lay pipe uniformly to line and grade so that the finished sewer presents a uniform bore. Noticeable variations from true alignment and grade will be sufficient cause for rejection of the work.

Commence at the lowest point and proceed to the upper end. Lay pipe with bell-end pointing up-grade.

When work is stopped for any reason, securely plug the end of the pipe.

8.3.08 SEWER STRUCTURES

The interior bottom of manholes shall be constructed of concrete fillets poured-in-place in the field. Flow lines shall be made smooth with uniform curves to promote flow through the manhole and shall extend from invert to invert. Sewer mains shall project a minimum of two inches (2") inside the manhole wall and in all cases where possible, shall extend through the manhole to aid in finishing of the manhole bottom. Pre-cast inverts shall be allowed if approved in advance by the Engineer. Engineer retains sole discretion as to acceptability of pre-cast inverts as installed. Mortar all pipes in manholes.

Outside Sewer Drops entrances shall be installed where indicated on drawings. Outside drops shall be used and shall be of the same diameter as the sewer main for pipe 12 inch and smaller.

Sanitary sewer structures shall have a minimum of three inches (3") and a maximum of nine inches (9") of adjusting rings. Adjusting rings shall be installed per manufacturer's specifications and as herein specified. Prior to installation of adjusting rings, clean top of concrete structure of debris. Create a flat sealable surface using non-shrink mortar (4,000 psi) if the top of the cone is too badly chipped to install the rings correctly. Install pre-compressed butyl rubber 3/8" x 3.5" between structure and first ring where the flat area of the ring will be in contact with the structure for the entire 360 degrees, one (1) 1/4" bead of sealant or 3/8" round butyl sealant rope on the entire 360 degrees of each rings male lip, and install pre-compressed butyl rubber 3/8" x 3.5" on top of the upper ring in a location so that it contacts the cover frame the full 360 degrees. Make sure all loose rust is removed from the casting before it is placed on the adjusting rings. All adjustment for matching road grade shall be made by utilizing a molded and indexed slope ring. Use of mortar or shims, or modifying adjusting rings to match road grades is prohibited.

Internal chimney seals shall be installed per manufacturer's specifications in all manhole structures.

8.3.09 CASTINGS

Sanitary manhole castings, in roadways temporarily receiving binder coarse only, shall be set to binder grade. Sanitary manhole castings shall be set 1/4" below final grade in all other areas unless otherwise directed by Engineer. "Scab" and monolithic ramping is prohibited.

Sanitary manhole castings set to binder grade, shall be brought to 1/4" below surface grade immediately prior to placement of surface coarse, with non-rocking cast iron adjustment rings.

8.3.10 SANITARY SEWER LATERALS

Unless otherwise stated by Engineer, service laterals shall be installed within the right-of-way or easement to serve all existing buildings and all platted lots. Service laterals shall consist of a branch fitting at the main and extension of the specified lateral pipe to the end of lateral as called for and requested. All necessary fittings shall be furnished and installed to complete the installation.

All sanitary sewer service lateral connections to existing sanitary sewer mains, of non-PVC material, shall be cored and an Inserta Tee, or approved equal connector, shall be installed per manufacturer's instructions unless otherwise directed by Engineer. For sanitary sewer lateral connections to existing PVC sanitary sewer mains, SDR 26 wyes shall be cut in and installed with the use of SDR 26 couplings. Use of Ferncos is prohibited on PVC pipe.

Lay sewer laterals uniformly to line and grade so that the finished sewer presents a uniform bore. Noticeable variations from true alignment and grade will be sufficient cause for rejection of the work. Commence at the lowest point and proceed to the upper end. Lay lateral pipe with bell-end pointing up-grade. When work is stopped for any reason, securely plug the end of the pipe.

The ends of all laterals shall be plugged to resist air test pressure. All plugs shall be manufactured to fit the pipe used and shall be watertight.

Laterals shall be extended 10 feet beyond the right-of-way or easement line, whichever is further from the roadway centerline, and be a minimum of 12 feet deep at the property line unless directed otherwise by Engineer.

Risers may be installed on laterals that have excessive depth. Risers shall be installed by tilting the wye, extending lateral pipe, and then installing a 22.5-degree bend to get the lateral on grade.

The sanitary lateral stubs shall be marked with a 4" x 4" wood post, placed vertically at the invert and extending two feet (2') above ground. All sanitary lateral stubs shall be painted green.

Locating markers shall be installed directly above sanitary laterals two feet from property line (within right-of-way) and at all horizontal bends. Markers shall be installed 2.5' and 3.5' from final surface elevation. Markers shall be checked for conductivity prior to installation of streets.

See Section 7.3.10 for sanitary sewer lateral distance requirements from water services.

8.3.11 ABANDONMENT

- A. Sanitary Sewer Mains.** Sanitary sewer mains, to be abandoned, shall be capped unless otherwise directed by Engineer.
- B. Structures.** The casting, all adjusting rings, and the top three feet (3') of the structure shall be removed. Castings are the property of the City. A hole shall be cut into the bottom of the structure to accommodate drainage through the structure. All openings within the structure shall be plugged with concrete. The entire structure shall be completely filled in with granular material or cellular concrete. All disturbed areas shall be backfilled with the required backfill material.
- C. Sanitary Sewer Laterals.** Sanitary sewer laterals, to be abandoned, shall be capped unless otherwise directed by Engineer. Sanitary laterals shall be abandoned at the

main unless otherwise directed by the Engineer. Laterals that are located under hard surfaces shall be capped as close to the street edge as allowable and an approved three foot (3') liner shall be installed in the main to seal off the lateral as directed by the Engineer.

8.4 FIELD QUALITY CONTROL AND TESTING

8.4.01 TESTING REQUIREMENTS

All sanitary sewers shall be mandrel tested, low-pressure leakage tested, and televised.

8.4.02 TELEVISIONING

All sanitary pipe eight inches (8") and larger and all structures shall be televised.

Closed circuit television shall be utilized for inspecting the interior of all completed sections of the mains. Televising shall take place after all utilities are installed, backfilled and compacted, all sanitary sewer has been cleaned, and prior to placement of any hard surfaces. Flash drive recordings of these inspections and written and pdf logs of same shall be submitted to and reviewed by the Engineer five business days prior to the placement of any hard surface. The recordings and written and pdf logs submitted to the Engineer shall exclusively be for sanitary sewer, flash drives and written and pdf logs for sanitary sewer shall be submitted separately. Inspection records shall be of suitable format, and shall include, but not necessarily be limited to, the following data:

Project Title, Owner Name
Date of Inspection, Type of Pipe and Size
Weather
Names of Inspectors and Technicians
Location of Line
Manhole Numbers, Section Length
Direction of Inspection and Measurements
Location, size, and direction of all laterals, including laterals extending from manholes
General Condition of Line
Deflections (vertical and horizontal)
Joint Conditions
Points of Infiltration, Locations of Obstructions

The television camera used shall be specifically designed and constructed for sewer inspection and shall take picture in color. Black and white imagery shall not be accepted. Lighting for the camera shall be operative in 100 percent humidity conditions. The camera shall have a minimum of 720x480 resolution. Picture quality and definition shall be to the complete satisfaction of the Owner. The improvements shall not be eligible for acceptance prior to Contractor's submission of televising records which are deemed satisfactory by the Owner.

The Contractor shall, prior to televising, deposit into the new sewer mains and services a minimum amount of water as directed by the Engineer to allow for indication of sags in the pipe.

Flash drive records shall be made of all sections of the new sewer main and services. The video shall be made continuously as the camera is pulled or driven through the line and shall include a panorama view of each manhole, each pipe connection to the manhole, each lateral, and each defect. Each recording shall be in flash drive format, and shall be numbered and dated. A list shall be provided on the container for each flash drive indicating the flash drive number, project name and sections of sewer included. All

recordings shall be made on new flash drives and the flash drives shall become the property of the Owner. The Contractor shall be responsible for supplying all safety equipment necessary to complete the work in compliance with applicable OSHA and IHLR standards.

8.4.03 LOW PRESSURE LEAKAGE TESTING

The leakage test shall conform to the requirements of WUCA Specifications, Chapter 3.7.0. The costs of this work shall be at Contractor's expense.

8.4.04 MANDREL TESTING

A deflection testing mandrel shall be used to determine whether the vertical deflection of installed polyvinyl (PVC) sewer pipe exceeds the maximum allowable vertical deflection. The deflection of the pipe shall not exceed that which will permit the free passage of the mandrel through the pipe. The mandrel specifically designed for SDR 26 shall be used. Testing shall take place thirty (30) days after pipe installation unless directed otherwise by Engineer. All pipe that exceeds the maximum vertical deflection shall be repaired, backfilled, and mandrelled by Contractor prior to acceptance. The costs of this work shall be at Contractor's expense.

END

SECTION 9 – STREET LIGHTING, TRAFFIC SIGNALS, AND SIGNAGE

9.1 GENERAL

9.1.01 RELATED DOCUMENTS

City of Madison Standard Specifications for Public Works Construction Part VI: Traffic Engineering Electrical & Pavement Markings, latest revision for traffic signals and street lighting only. <https://www.cityofmadison.com/engineering/developers-contractors/standard-specifications>

Manual of Uniform Traffic Control Devices (MUTCD), latest revision at <http://mutcd.fhwa.dot.gov/>

9.1.02 DESCRIPTION OF WORK

The Contractor shall be responsible for production and approval of Shop Drawings; ordering, delivery, and coordination with MGE and Alliant Energy as indicated below for each individual light style; and for conformance with the Specifications contained herein and the Plans. The Engineer reserves the right to modify the Specifications as necessary for each individual project.

9.2 MATERIALS

9.2.01 ORDERING AND PURCHASING

The materials specified are for information purposes only. Unless stated elsewhere, all street lighting materials will be ordered and purchased directly by the Developer. Developer shall ensure that the original manufacturer's warranty is transferred to the City at the time of or prior to the City's acceptance of improvements.

9.2.02 TYPE A - RESIDENTIAL (29' Concrete Pole, 6' Arm, Green Cobra)

- A. Fixture Ordering Information:** Green Cobra LED GC1 F-Series #GC1-40F-MV-NW-3-GY-700-PCR7-CR7-WL
LED Count: 40 (40F)
Voltage: 120-277V (MV)
Color Temperature: 4000K (NW)
Distribution: Type 3 (3) (dependent on photometrics)
Finish: Gray (GY)
Drive Current: 700mA (700)
Options: Control Ready 7-wire Photocontrol Receptacle (PCR7-CR7)
Utility Wattage Label (WL)
Photoeye: Intermatic Inc. Part#EK4536 (Ordered Separately)
- B. Pole:** Traditional Concrete Inc. octagonal 100 series D124-MG-PA
Material: Madison Gray concrete polish finish with water based acrylic seal.
Embedment: Direct, 5' burial required
Dimensions: 29' overall, 24' mounting
- C. Arm:** 6' aluminum davit arm with 2-3/8" outside diameter

9.2.03 TYPE B – COMMERCIAL/RESIDENTIAL (30' Aluminum Anodized Pole, Concrete Base, Breakaway)

A. Fixture A: Leotek LED AR13-48N-MV-NW-2-DB-160-PCR

Product: 13N Series (AR18)

LED Code: 48N

Voltage: 120-277V (MV)

Nominal Temperature Color: 4000K (NW)

Distribution: Type 2 (2)

Fixture Finish: Dark Bronze (DB)

Output Code: 160

Photocontrol: NEMA Photocontrol Receptacle (PCR)

Pole Adaptor: Leotek RRPA-DB

B. Pole: HAPCO RTA30C8B4-A3X

Material: Spun-Tapered Aluminum Alloy tubing

Finish: Medium Bronze Anodized

Nominal Mounting Height: 30 feet, Shaft Outside Diameter: 8"

Vibration Damper: Option "V" required

Fixture holes: pre-drilled

C. Transformer Base: HAPCO 70512P MB, medium bronze powder coat finish to match pole.

D. P.C. Sensor: Intermatic EK4536K (ordered separately)

Orientation: North

9.2.04 TYPE C – RESIDENTIAL/COMMERCIAL (30' Galvanized Steel Pole, 10' Arm, Green Cobra, Concrete Base, Transformer Base)

A. Fixture Ordering Information: Green Cobra LED GC1 F-Series #GC1-40F-MV-NW-

3-GY-700-PCR7-CR7-WL

LED Count: 40 (40F)

Voltage: 120-277V (MV)

Color Temperature: 4000K (NW)

Distribution: Type 3 (3) (dependent on photometrics)

Finish: Gray (GY)

Drive Current: 700mA (700)

Options: Control Ready 7-wire Photocontrol Receptacle (PCR7-CR7)

Utility Wattage Label (WL)

Photoeye: Intermatic Inc. Part#EK4536 (Ordered Separately)

B. Pole: Galvanized Steel tapered round pole

Millerbernd Manufacturing Co. #11RA803830-2BS-001-GV mast arm attachment 730B1250

Dimensions: 30' pole with arms mounted 6" below top

C. Arm: Hapco 12' truss bracket drawing #B25413

D. Transformer Base: Valmont TB2-17 satin finish

9.2.05 TYPE D – PEDESTRIAN SCALE (14' Concrete Pole with Washington Fixture)

- A. Fixture:** King Luminaire K118 Washington - LED
Luminaire Style: Washington (K118R)
Optical: Flat Array (P4)
Lens: Acrylic Rippled (AR)
IES Lighting Classification: Type 5 within medians (V)
Type 3 at all other locations (III)
Wattage: 100 (100)
Source: Solid State (SSL)
Series: 40-100W (1030)
Line Voltage: 120V (120:277)
Pole Adaptor: Cast Aluminum (K6/K9)
Decorative Option: Solid Spun Top (SST)
Photo Control: Seven Pin Photo Receptacle and Photo Eye (PE7)
CCT: Residential 3000K (3K)
Commercial 4000K (4K)
Paint Color: Black (BK)
Final Option: #2 (#2)
Wattage Selector: Required (WS)
House Shields: Required in Residential Areas, except at intersections (LPS)
Connection: Quick Disconnect
Pre-wired Lead: 30' min. underground rated wire lead

- B. Pole:** StressCrete Group The Talisman #KT14-G-E11-DB S/F K6/K9
Material: Spun Concrete
Pole Style: Talisman Flared Top (KT)
Pole Height above Ground: 13' 11" (14)
Finish: Etched Finish (E)
Color: Eclipse Black (11)
Footing Details: Direct Buried (DB)
Pole Adaptor: Suited for K6/K9 fixture adaptor (S/F K6/K9)
Coating: Acrylic (A)
Options: GFI, Banner Arm, Flag Holders, etc. - Required if specified.
Handhole & Cover Plate: Cast Aluminum Box & Cover, 2-5/8"x8" minimum opening - located on sidewalk side of pole
Wiring Aperture: Minimum two 2.5"x9" openings - center of each box 18 inches below grade. Located on handhole side of pole.
Tip Dimension: 9-inches
Flare: 18-inch
Direct Bury Length and Diameter: 4'6" x 9.5"
Pole Weight: 1,370 lbs

9.2.06 METERED STREET LIGHT CONTROLLER

Cabinet shall be Millbank #CP3B5111FB22DGWESP, 120/240 VAC, 100 Amps max, single phase. Cabinet shall be dark green aluminum. Meter Socket shall be 41" ringless lever bypass style centered with a large "WE" window.

9.2.07 HANDHOLES

Handholes for street lighting shall be New Basis or approved equal fiberglass/polymer concrete assembly with tapered sides 17"x30"x24". The nameplate shall read "Street Lighting". For direct bury streetlights, add a New Basis handhole or approved equal polymer concrete 12"x12"x12" with straight sides behind the light pole in grass areas. Bolt down 12" diameter round polymer concrete handholes, approved by Engineer and MG&E, shall be provided for hard surface areas. Handholes shall be provided with Type A and Type D fixtures. Base for handholes shall be six inches of ¾" clear stone. Handhole bolts shall be 304 stainless steel.

Handholes for traffic signals shall be New Basis or approved equal fiberglass/polymer concrete assembly with tapered sides of the size indicated on the plans. If size is not indicated, handholes shall be 17"x30"x24". The nameplate shall read "Traffic Signals". Do not use bolts for traffic signal handhole lids. Base for handholes shall be six inches of ¾" clear stone.

9.2.08 CONDUIT AND CABLE

Conduit shall be Polyvinyl Chloride (PVC) Conduit Schedule 40 and Schedule 80, unless otherwise specified. Schedule 80 shall be used under all pavements and schedule 40 in all other locations unless otherwise specified.

PVC conduit shall be used in accordance with the National Electrical Code and shall comply with all requirements in NEMA Specifications TC-2 (Conduit) and TC-3 (Fittings-UL-514), Federal Specification W-C-1094A, UL-651 (Standard for rigid nonmetallic conduit), and ANSI C33.91.

The conduit and fittings shall be clearly marked with a UL label. The type and manufacturer shall be identified by legible and permanent markings.

The conduit and fittings shall be produced by the same manufacturer and be homogeneous, virgin PVC C-300 compound free from visible cracks, holes or foreign inclusions. The conduit bore shall be smooth and free of blisters, nicks, or other imperfections which could mar conductors or cables.

Conduit shall be installed within one foot (1') of the back of curb or as near as possible as allowed by the Engineer.

Under no circumstances shall cable ends be left uncovered or allowed to become submerged in water. Observations of either condition shall constitute sufficient grounds for rejection of the entire length of that cable.

Cable shall be installed in continuous lengths without splices from terminal to terminal. Splicing of cables will be permitted only in electrical handholes and electrical utility access structures, handholes in poles, and breakaway bases; or as otherwise provided in the plans.

9.2.09 STREET SIGNS

Street Name signs shall be a nine-inch (9") plate, double sided, and extruded aluminum material with high intensity prismatic (HIP) sheeting. Font and text height shall meet MUTCD requirements and shall be a combination of upper and lower case letters. Text heights shall generally follow these dimensions unless directed otherwise by Engineer:

- 6-inch upper case
- 4.5-inch lower case
- 3-inch suffix and prefix
- Abbreviations shall be used whenever possible (Rd, St, Dr, Ln, Cir, etc.)

Provide shop drawings of all street name signs and hardware to Engineer for final approval prior to ordering.

Advance Street Name signs shall be single sided, either 15" (minimum) flat aluminum or plywood, depending on the overall length of the sign, and shall have a 3/4" white border with High Intensity Prismatic sheeting. A minimum of 6" free space shall be provided between the end of the longest street name and the edge of the sign. Text height shall be similar to the 9-inch plate street name signs.

Overhead Street Name signs that are mounted to traffic signal arms or cantilevered arms shall be single sided, 18" (minimum) flat aluminum with no border and High Intensity Prismatic sheeting. Text heights shall be the following. If total sign area exceeds 11.25 sf with preferred text height, use minimum text heights to keep sign less than 11.25 sf:

- 12-inch upper case preferred; 9-inch minimum
- 9-inch lower case preferred; 6-inch minimum
- 6-inch suffix and prefix preferred; 4.5-inch minimum

Regulatory signs shall meet the minimum size requirements of MUTCD and shall be provided with High Intensity Prismatic (HIP) sheeting.

Warning signs shall meet the minimum size requirements of MUTCD and shall be provided with Diamond Grade (DG) sheeting.

Street light sign brackets shall be KC-500 model, Tapco product no. 109-00500, and 12-inch extruded cross pieces shall be Tapco Product Number 037-00003 or approved equal by Engineer.

9.2.10 SIGN POSTS

Treated 4"x4" wood posts shall be used for all signs that are placed within pervious surface areas (terraces, grass medians, etc). 2-3/8" galvanized steel posts shall be used for all signs that are placed within impervious surface areas and shall be installed with a V-Loc (23-VR1) base (concrete). Posts shall be inserted a minimum of 6 inches and a maximum of 9 inches into V-Loc socket. V-Loc socket shall be kept free of asphalt and concrete.

9.3 EXECUTION

9.3.01 DELIVERY AND INSTALLATION

- A. Lighting in New Plats in the MG&E Maintenance Area.** Installation of street lighting, wiring and appurtenances shall be completed by MG&E. City staff will coordinate the installation with MG&E. The street light base shall be installed by the contractor. All energizing shall be done by MG&E.
- B. Lights in New Plats in Fitchburg Maintenance Area.** All work shall conform with the latest edition of the City of Madison Standard Specification for Public Works Construction. All work shall be performed by a Licensed Electrician and approved by the City. Once the cabinet and meter base has been installed, contact Fitchburg

Building Inspection at 608-270-4240 for inspection. Building Inspection will notify the service provider.

- C. Lighting in Existing Streets/Parks and/or Alliant Service Area.** These areas will be handled on an individual basis. The City allows the underground and all other appurtenances related to the street lighting to be bid. All work shall conform with the latest edition of the City of Madison Standard Specification for Public Works Construction.

City staff must be contacted a minimum of 15 days prior to intended commencement of wiring or light installation activities to allow for City's authorization to proceed for MG&E and subsequent scheduling.

9.3.02 STREET LIGHT LOCATION

Street light poles and/or bases at intersections shall be located such that the horizontal distance between the center of pole or base, and the back of curb, is 54 inches, or as designated by the Engineer. Street light poles and/or bases, which are not located at intersections, shall be placed such that the horizontal distance between the center of pole or base, and the back of curb, is 42 inches, or as designated by the Engineer. Concrete bases shall be level and extend three inches (3") above the ground.

9.3.03 CONCRETE BASES

- A. TYPE B & C Concrete Bases.** Concrete bases shall be constructed by the Contractor in accordance with *City of Madison Standard Specifications for Public Works Construction*, latest revision, Type LB-3, with the following modifications:

- 1" x 40" Anchor bolts with 6" of thread at top and 4" L-Bend at bottom.
- 11.5" Bolt Circle (Unless Otherwise Specified)
- Anchor bolts are not furnished by the City

Concrete base forms shall be stripped to 12 inches below grade on the low side.

9.3.04 STREET SIGNS

- A. Signs on Wood Posts:** Bury wood posts a minimum of 36" inches into the ground. Mounting heights shall follow the MUTCD.
- B. Signs on Metal Posts:** Median island noses shall be integral and include V-Locs to add metal sign posts. Mounting heights shall follow the MUTCD. V-Locs shall be approved by Engineer.
- C. Signs on Street Light Poles:** Whenever possible, street name signs shall be mounted on street light poles at 12 feet from ground level to the bottom of the lowest sign. The street name sign with the longer name shall always be placed on the bottom. **Street signs shall be supported with street light sign brackets on the top of the upper sign and bottom of the lower sign. Signs shall have a 12-inch cross brace between them.**

END

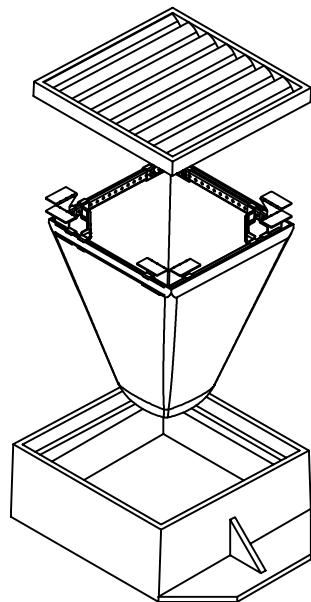
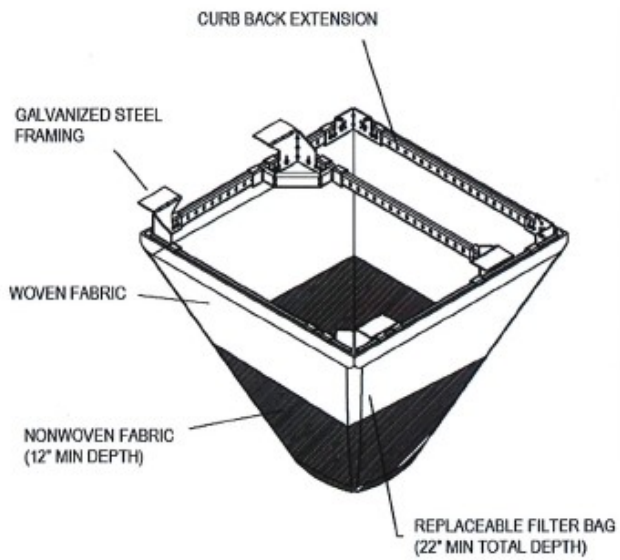

INSTALLATION:

1. REMOVE GRATE.
2. DROP INLET FILTER ONTO LOAD BEARING LIP OF CASTING OR CONCRETE STRUCTURE.
3. REPLACE GRATE.

BOULDER RETAINING WALL DETAIL

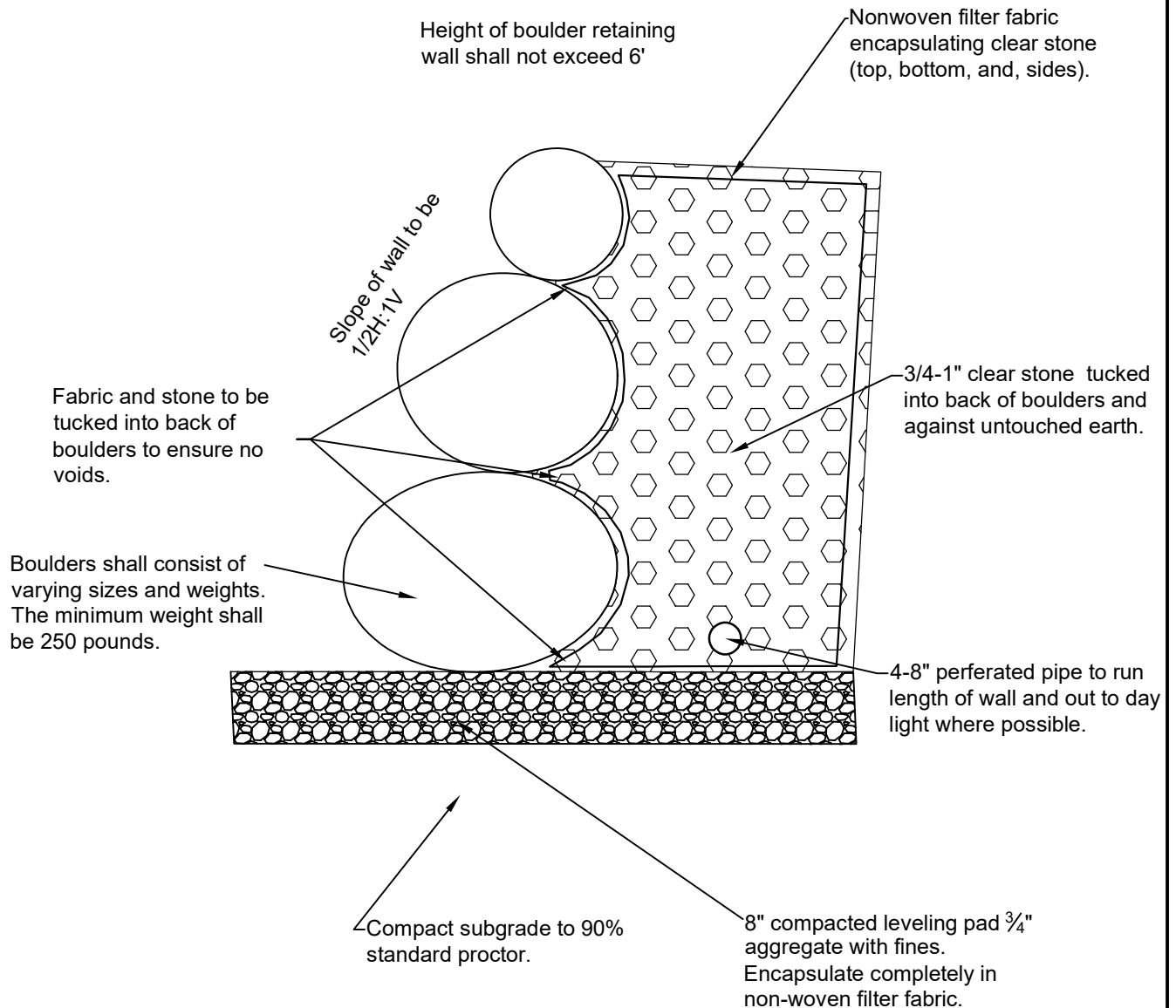

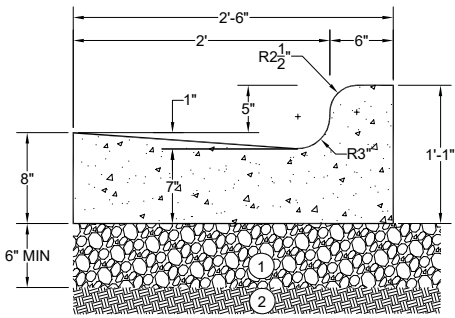

30" CONCRETE CURB & GUTTER

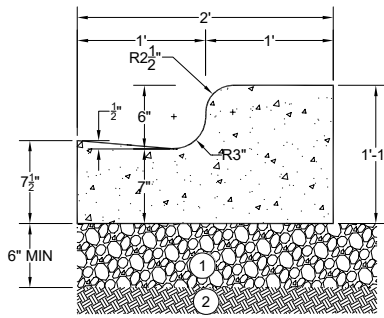

24" CONCRETE CURB & GUTTER

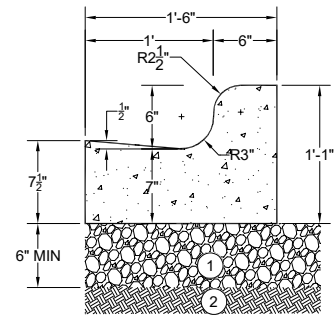

18" CONCRETE CURB & GUTTER

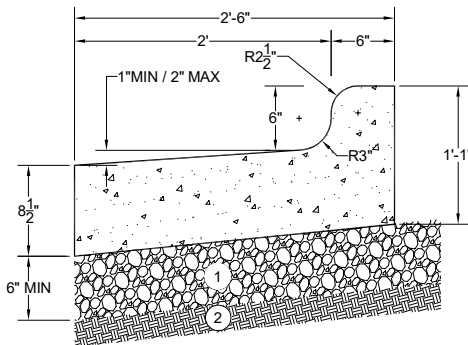

30" C&G REJECT SECTION

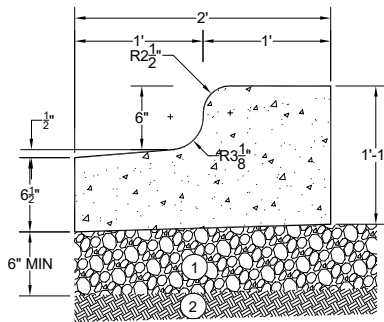

**24" C&G
REJECT SECTION**

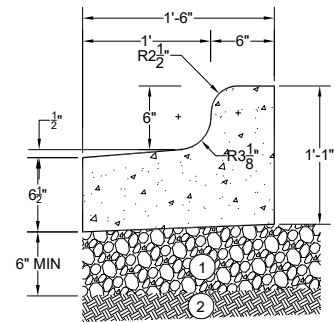

**18" C&G
REJECT SECTION**

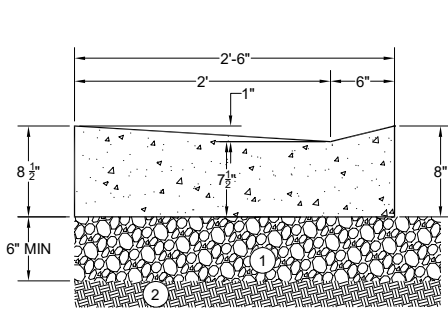

30" DRIVEWAY SECTION

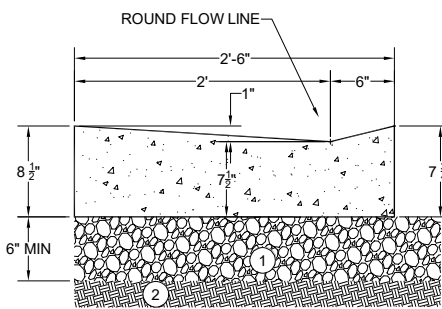

30" BIKE/PED RAMP SECTION

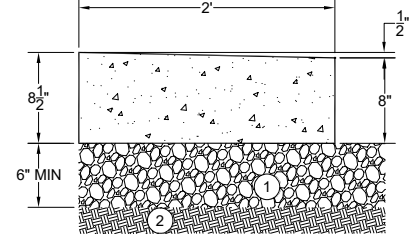

24" GUTTER

- ① Dense Graded Base Per Detail 5.01. Shall be provided 12-inches beyond the back of curb
- ② Compacted Sub Base

GENERAL NOTES FOR ALL SIDEWALK

1. Sidewalk thickness shall be 7-inches through driveways, 7-inches at ramps, and 5-inches for all public sidewalk.
2. Sidewalk cross-slope shall be 1.5% and not exceed 2.0%.
3. Provide a 1/2" expansion joint at all ramp locations, through driveways, against the curb and gutter, at radii, and every 96' of the sidewalk.
4. Construction forms shall be equal to or greater than the sidewalk thickness.

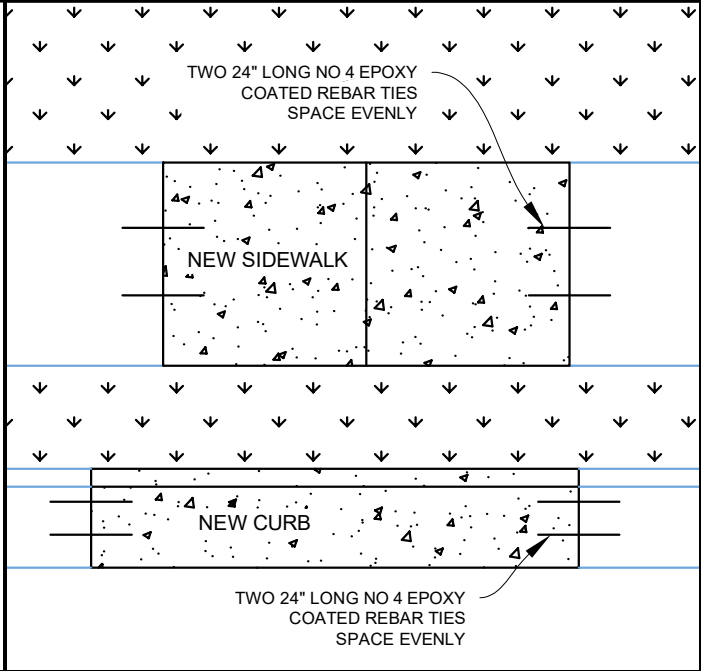
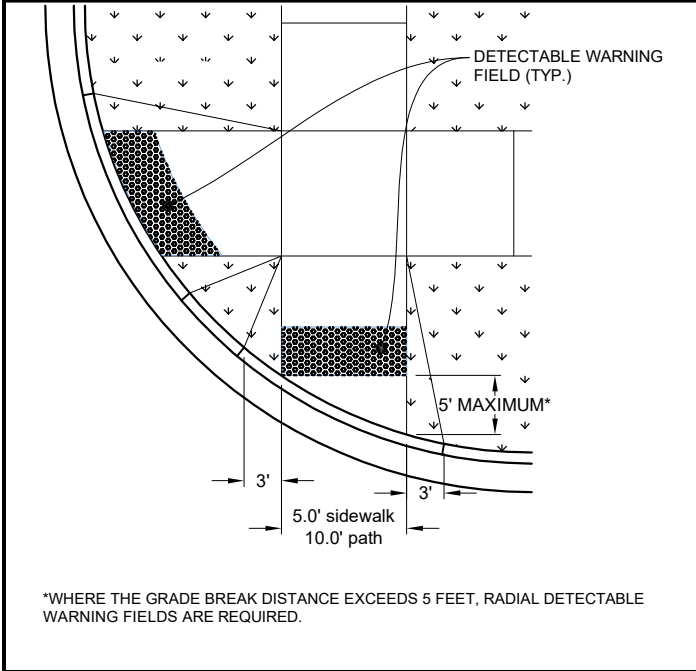
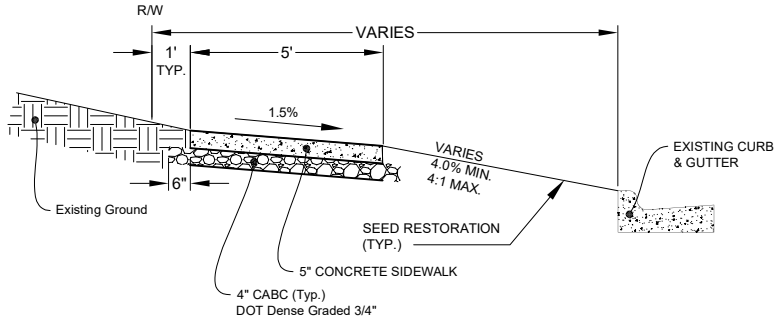

GENERAL NOTES FOR ALL SIDEWALK RAMPS

1. Install curb cuts at sidewalk ramps with either full removal and replacement or by "sawcutting" the curb head.
2. Curb tapers at curb cuts shall be 36" unless otherwise directed by the Engineer.
3. The width of the flat bottom of the ramp at the curb shall be 60" minimum.
4. The maximum slope of the ramp between the back of the curb and the front of the detectable warning field shall not exceed 2%. The maximum slope of the ramp between the front of the detectable warning field and the sidewalk shall not exceed 7%.
5. All handicap ramps shall include detectable warning fields with truncated domes.
6. Detectable warning field shall be oriented in a manner that it is parallel to the direction of pedestrian traffic. When curb is perpendicular to direction of pedestrian traffic, install detectable warning field tight to back of curb.
7. For a sidewalk ramp, detectable warnings shall be a minimum of 5' x 2'. For a bike path ramp, detectable warnings shall be a minimum of 10' x 2'.
8. Gore to be grass unless directed otherwise by Engineer
9. When conditions require more information, refer to "UFAS" (Uniform Federal Accessibility Standards). Where the grade break exceeds 5 feet, radial detectable warning fields are required.

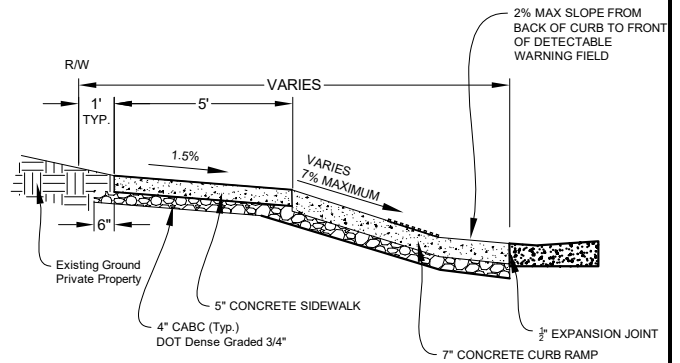

CURB RAMP TYPICAL SECTION

Commercial Driveway Detail

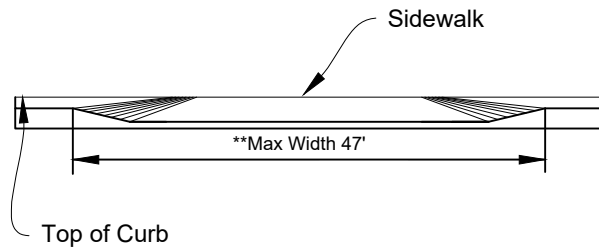

Section A-A

**Applicant may request an administrative variance for a commercial or industrial curb opening (excluding tapers) that is greater than 37' in width by providing documentation per City Ordinance 27-402 (b).

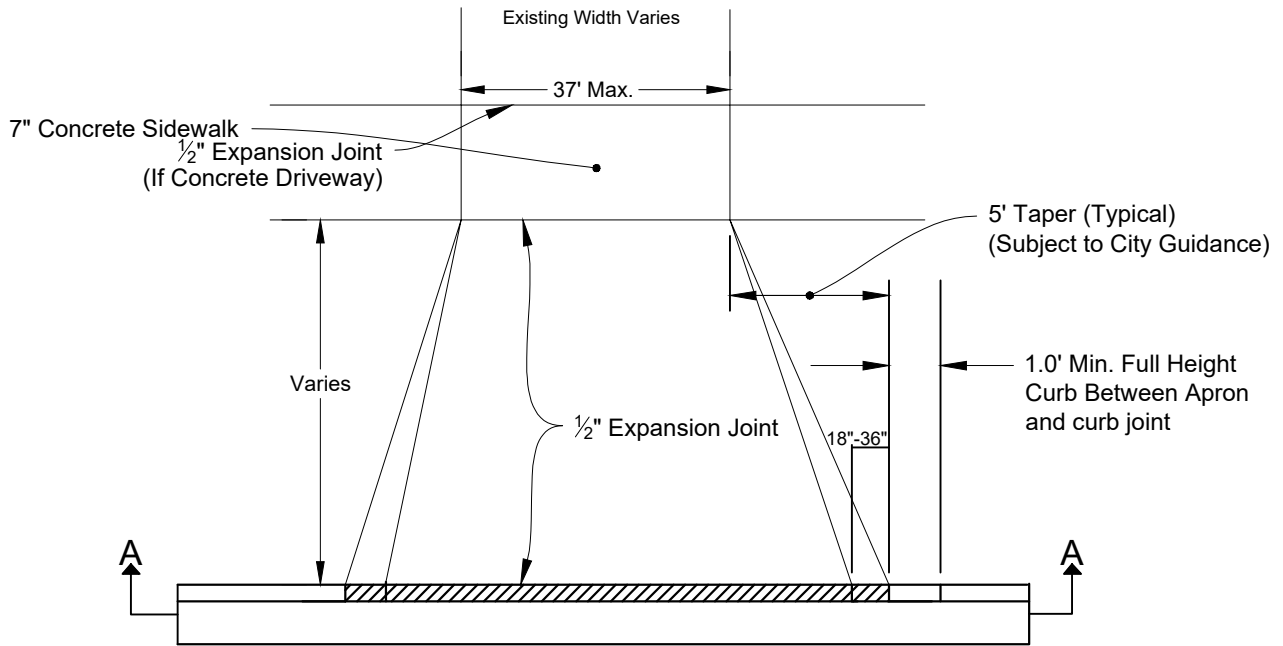

Plan

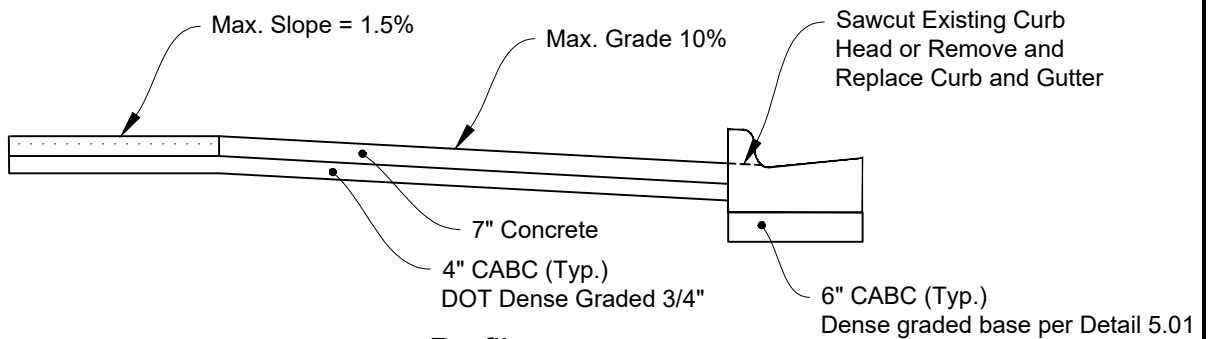

Profile



COMMERCIAL DRIVEWAY
STANDARD DETAIL DRAWING

DATE: 2/1/2017

SHEET NO.:

4.03

Urban Driveway Detail

Residential

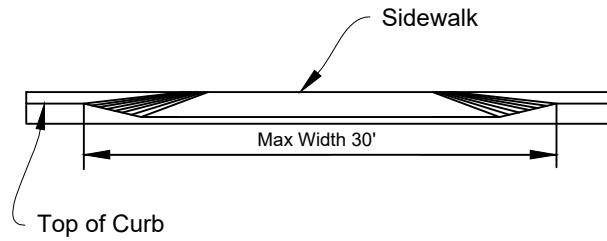

Section A-A

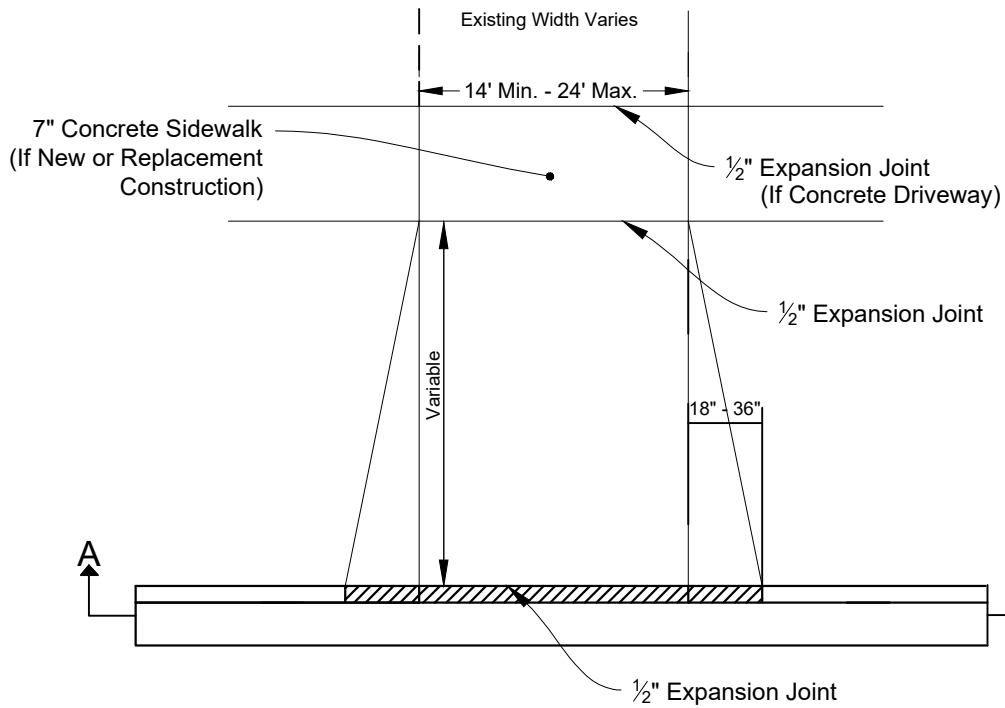

Plan

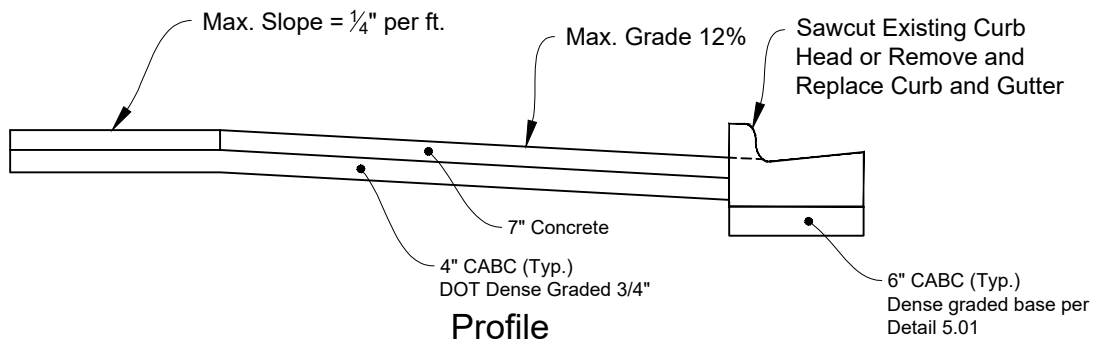

Profile

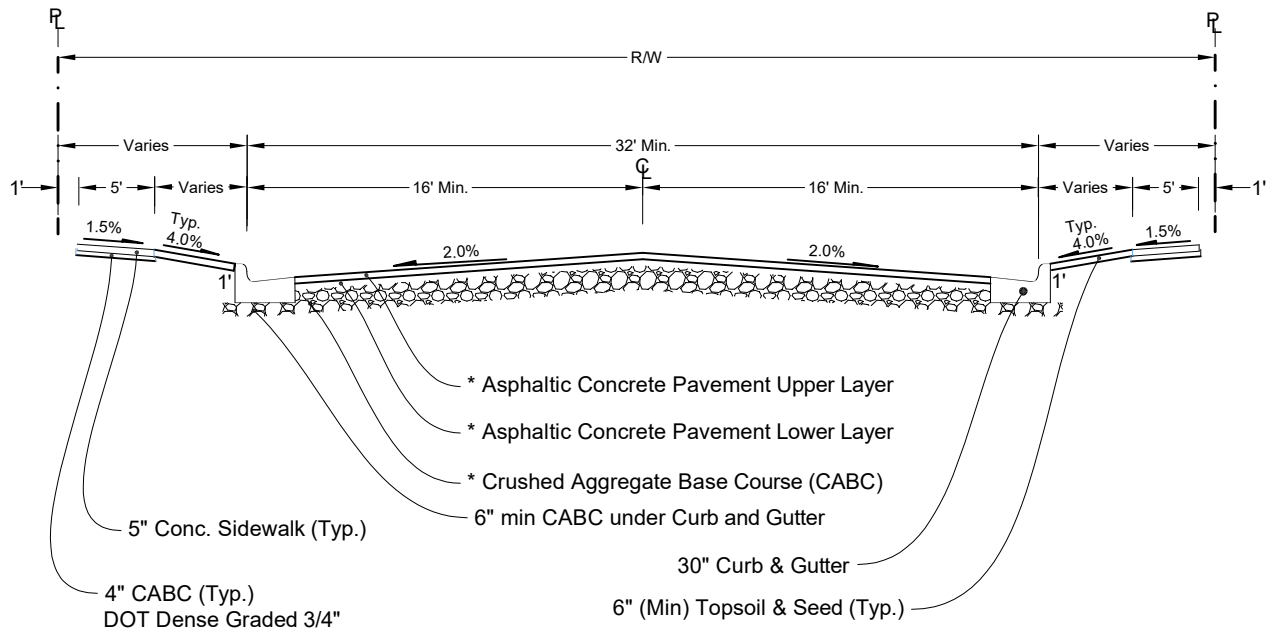

* City of Fitchburg Minimum New Pavement Design

Type	Crushed Aggregate Base Course		Asphaltic Concrete Pavement		Asphalt Material
	Lower Layer Dense 3"	Upper Layer Dense 1 1/4"	Lower Layer Type Thickness	Upper Layer Type Thickness	
Residential	7"-8"	4"-5"	LT 2 1/4"	LT 1 3/4"	58-28
Collector	7"-8"	4"-5"	LT 2 3/4"	LT 1 3/4"	58-28
Arterial	7"-8"	4"-5"	MT 3"	MT 2 1/4"	58-28

*Note: All cul-de-sac bulbs shall increase binder and surface by 1/4"

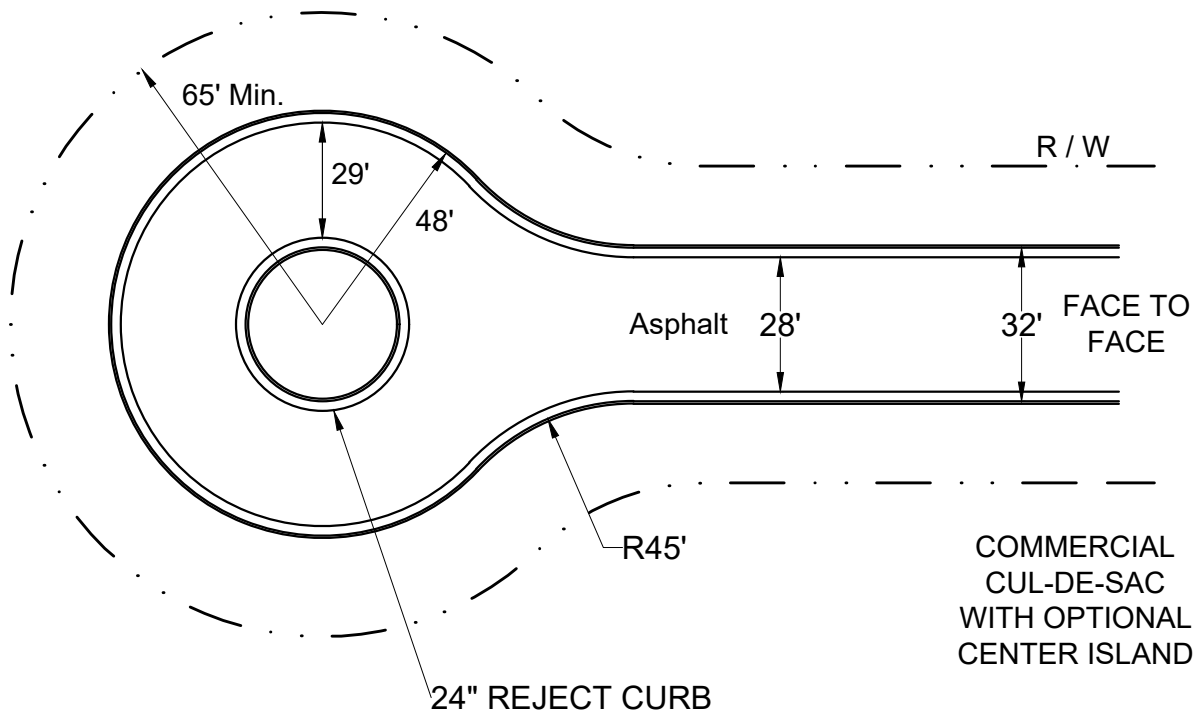
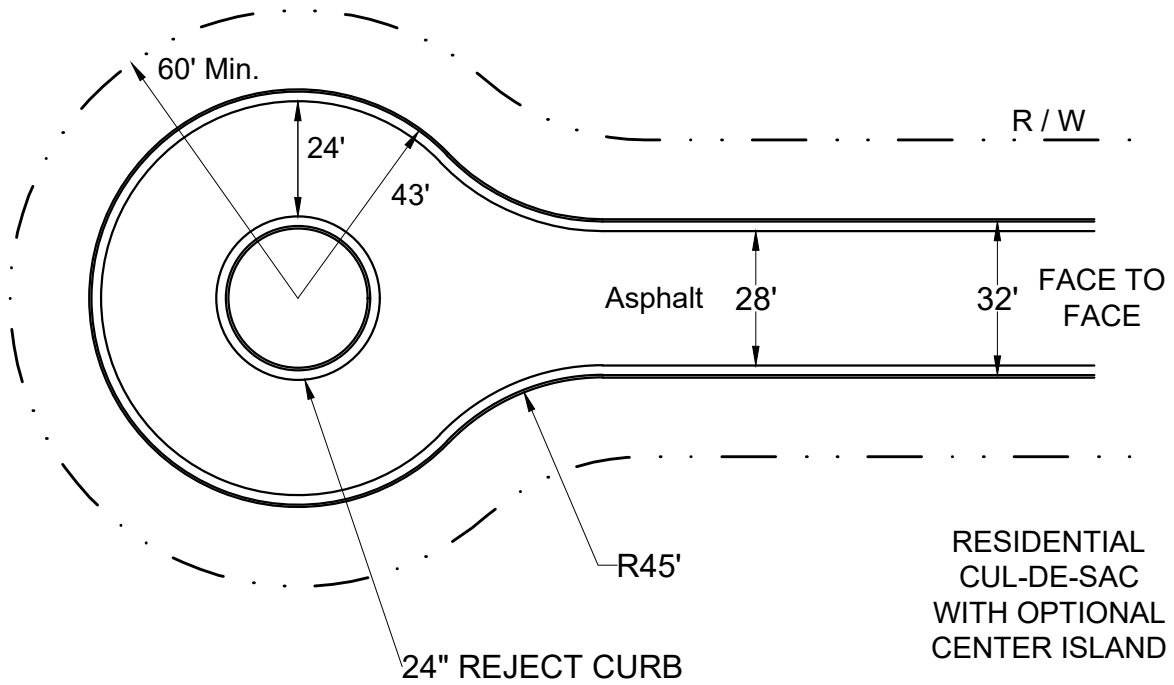

Rural Driveway Detail

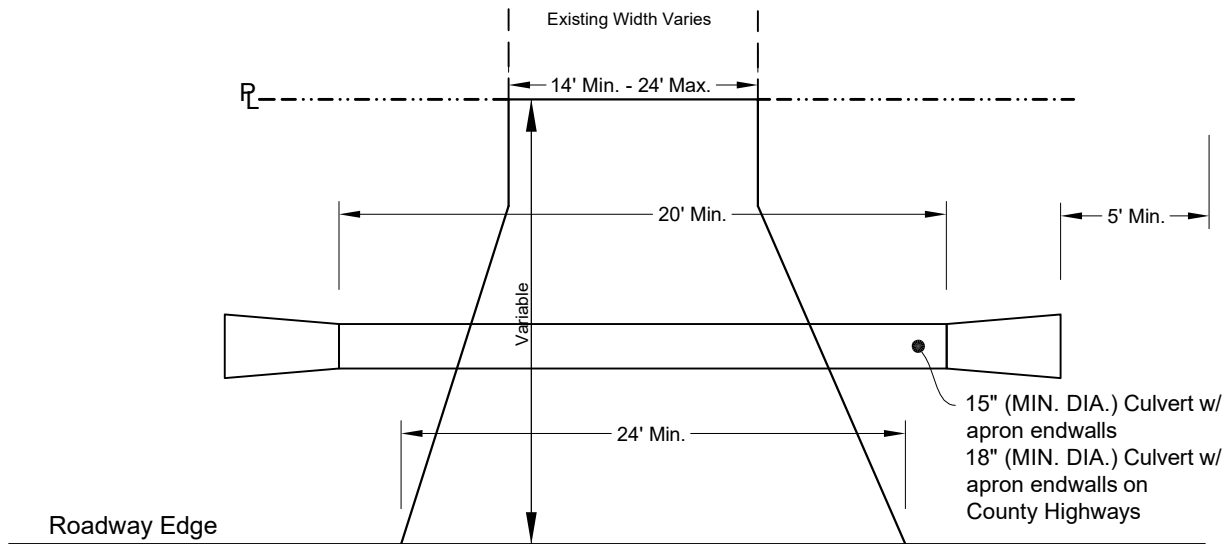

Plan

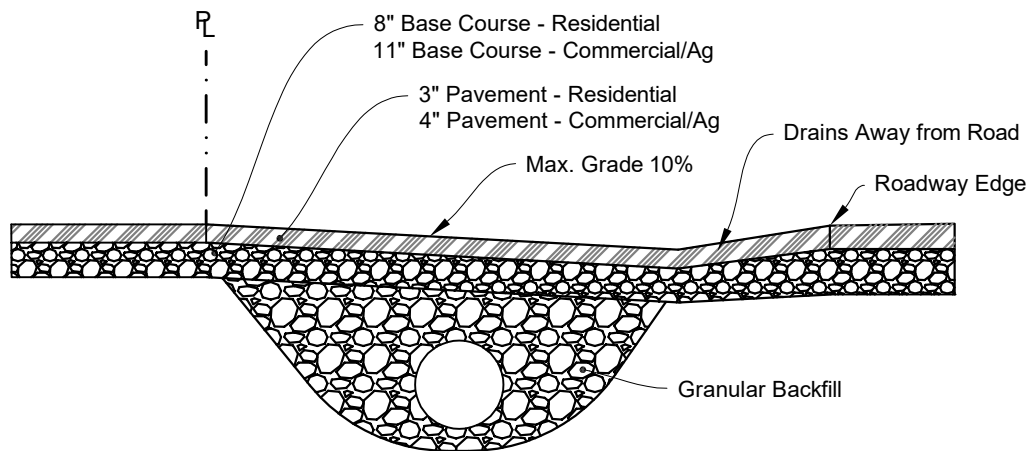

Profile

*20' Min. IF DRIVEWAY IS LONGER THAN 100'

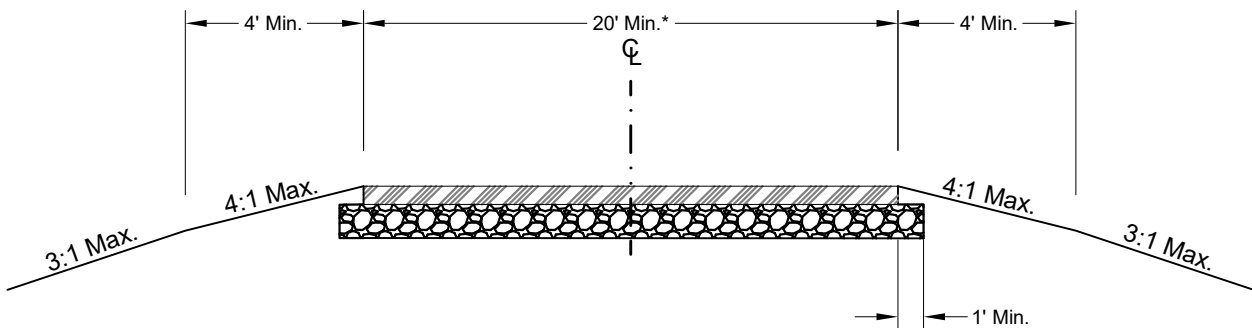

24" LONG NO 4 EPOXY COATED REBAR TIES 36" OC

SLOPED AREA

EXISTING CURB AND GUTTER

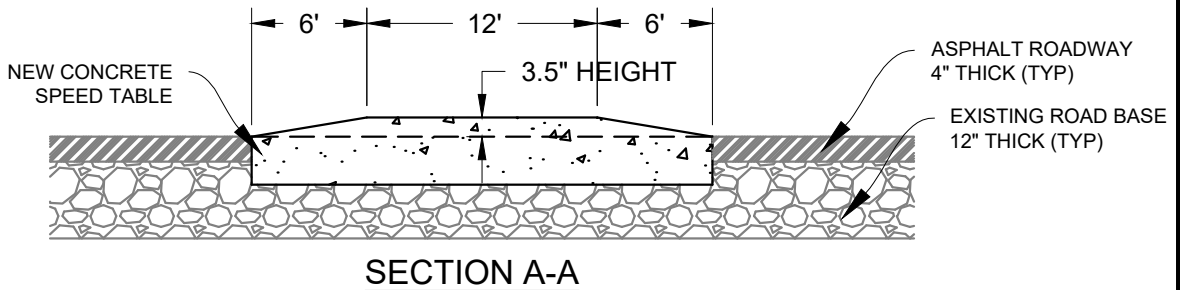
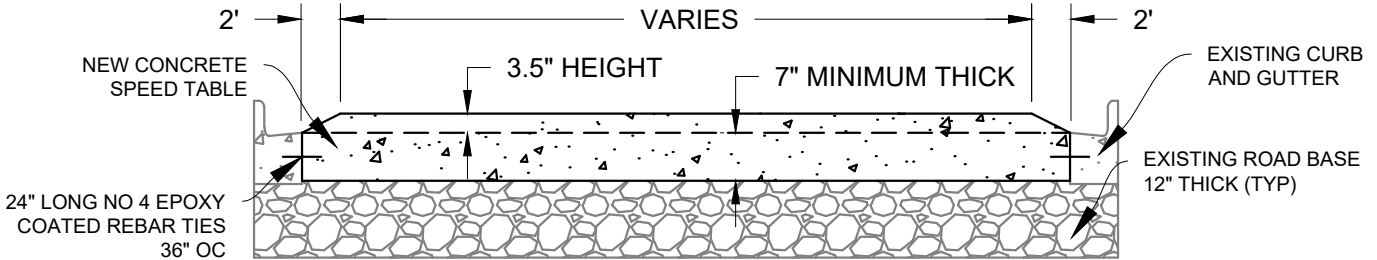
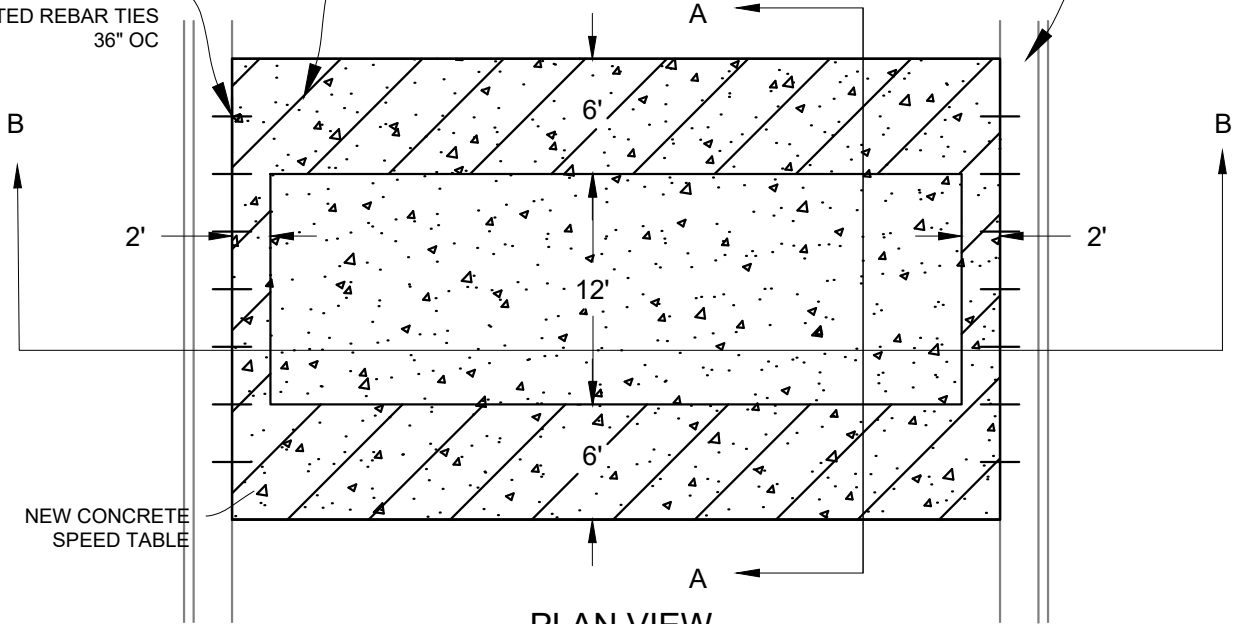

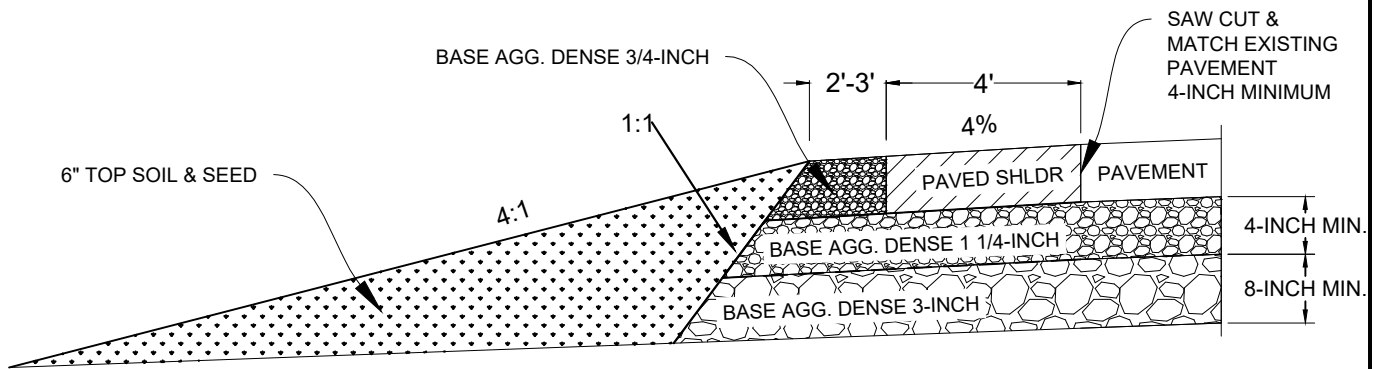

TYPICAL SHOULDER SECTION

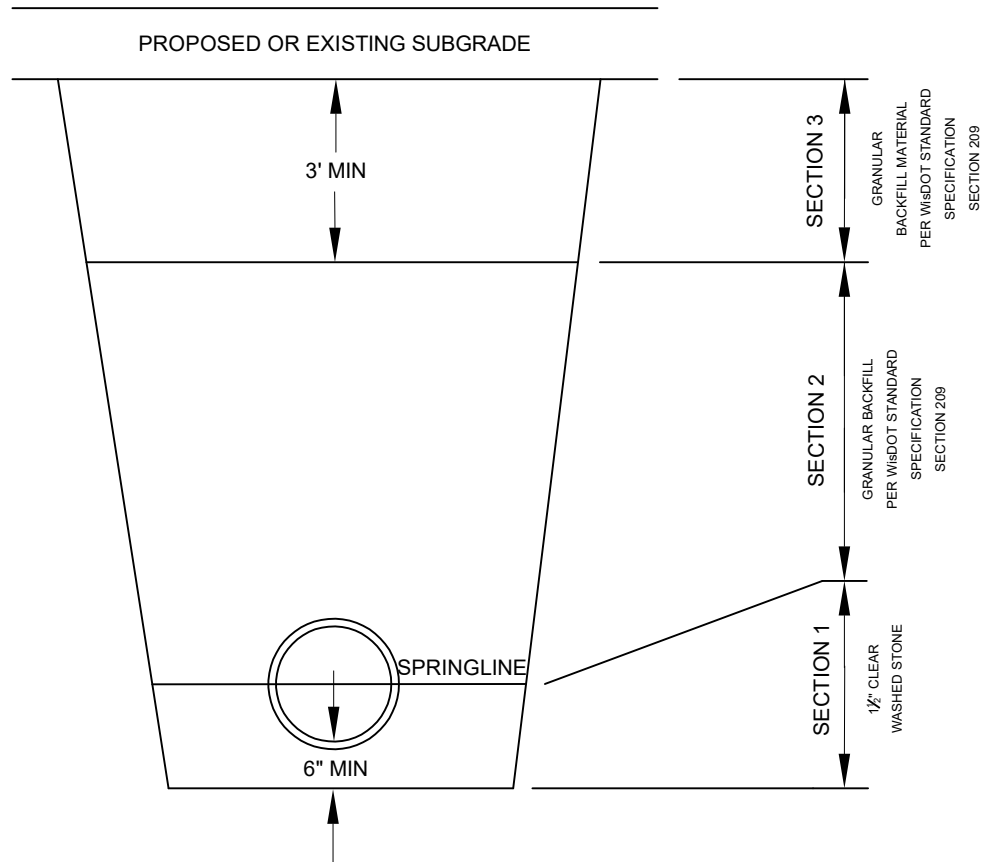

STANDARD TRENCH COMPACTION

ALL BACKFILL MATERIAL SHALL BE PLACED IN LIFTS NOT TO EXCEED 18" BEFORE COMPACTION UNLESS AUTHORIZED BY THE ENGINEER DUE TO THE CHARACTER OF THE MATERIAL AND THE COMPACTING EQUIPMENT. EACH LIFT SHALL BE MECHANICALLY COMPACTED TO THE REQUIRED DENSITY PRIOR TO PLACING SUCCEEDING LIFTS OF BACKFILL MATERIAL.

SECTION 1:
MECHANICALLY COMPACTED BEDDING AS REQUIRED BY THE SPECIFICATIONS. COMPACTION ACHIEVED WITH SMALLER PLATE COMPACTOR.

SECTION 2:
MINIMUM COMPACTION 90% MAXIMUM DENSITY. COMPACTION OF BACKFILL WITH BOMAG OR HOE-PAC SHALL NOT BEGIN UNTIL THE DEPTH OF BACKFILL MATERIAL IS TWO (2) FEET ABOVE THE TOP OF PIPE.

SECTION 3:
MINIMUM COMPACTION 95% MAXIMUM DENSITY.

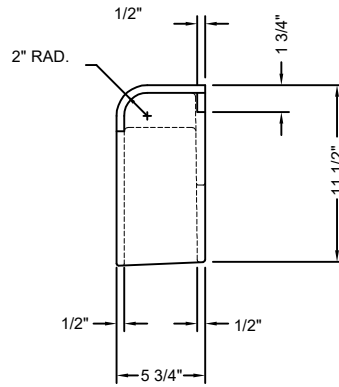
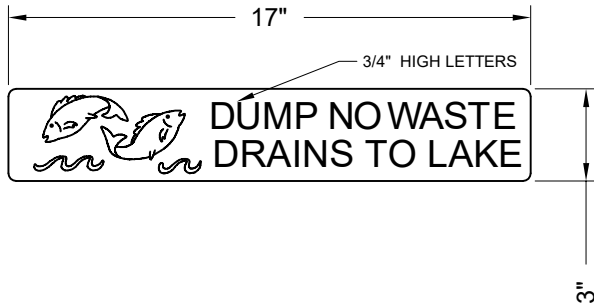

SIDE VIEW

NOTE: ALL DIMENSIONS SHOWN ARE IN ENGLISH
 MATERIAL: CAST GRAY IRON ASTM A-48, CLASS 35B
 FINISH: NO PAINT
 WEIGHT: 126#

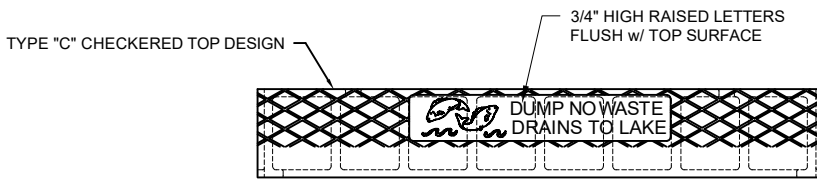

TOP VIEW

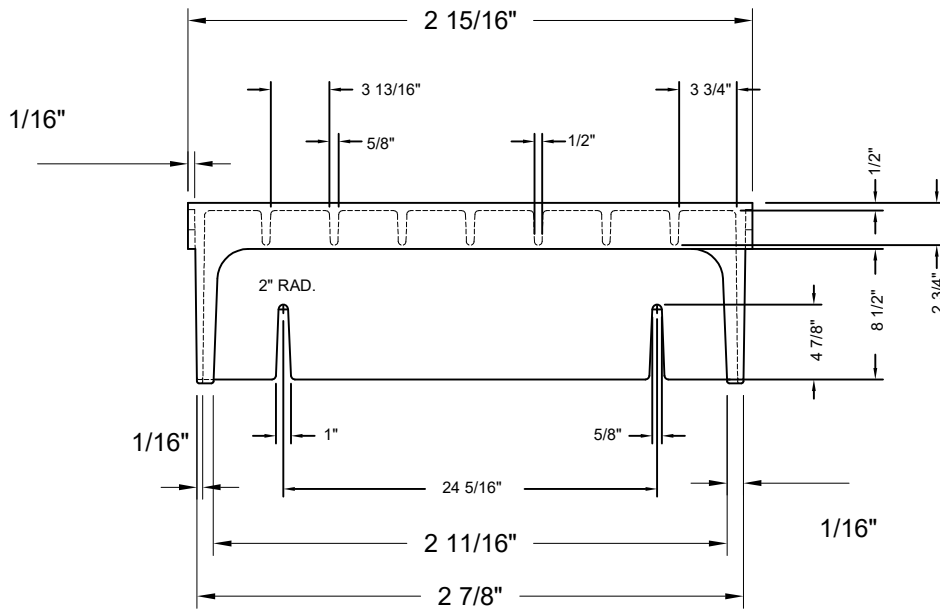

FRONT VIEW

Type L Grate

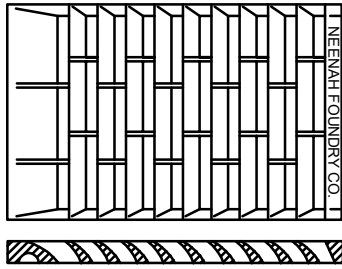

Vane Grate Openings

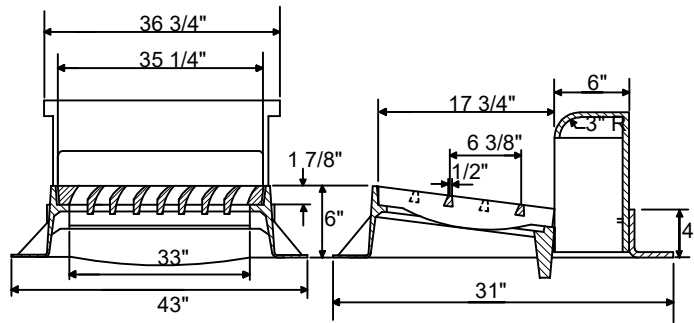

Type VB Grate

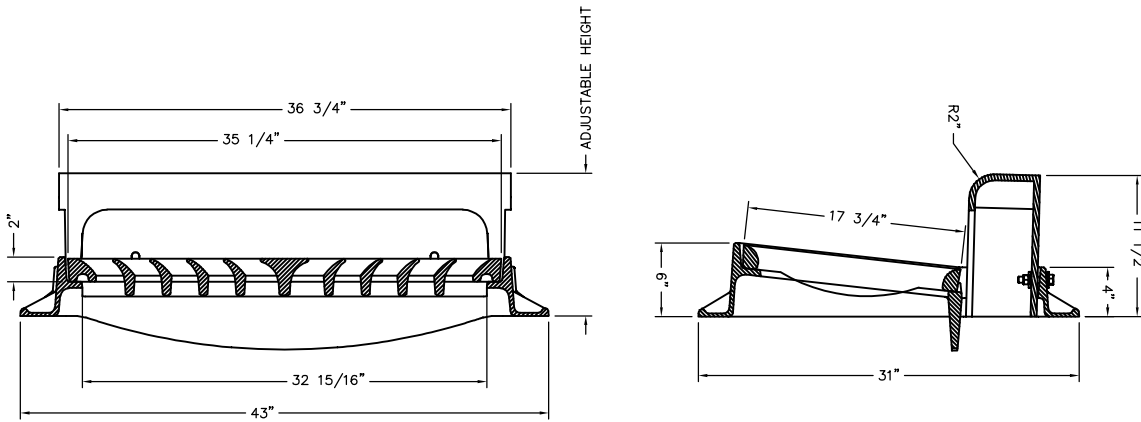
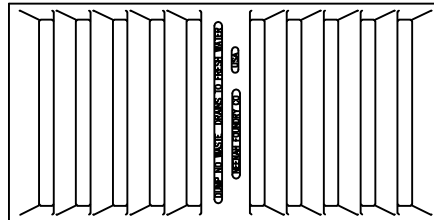

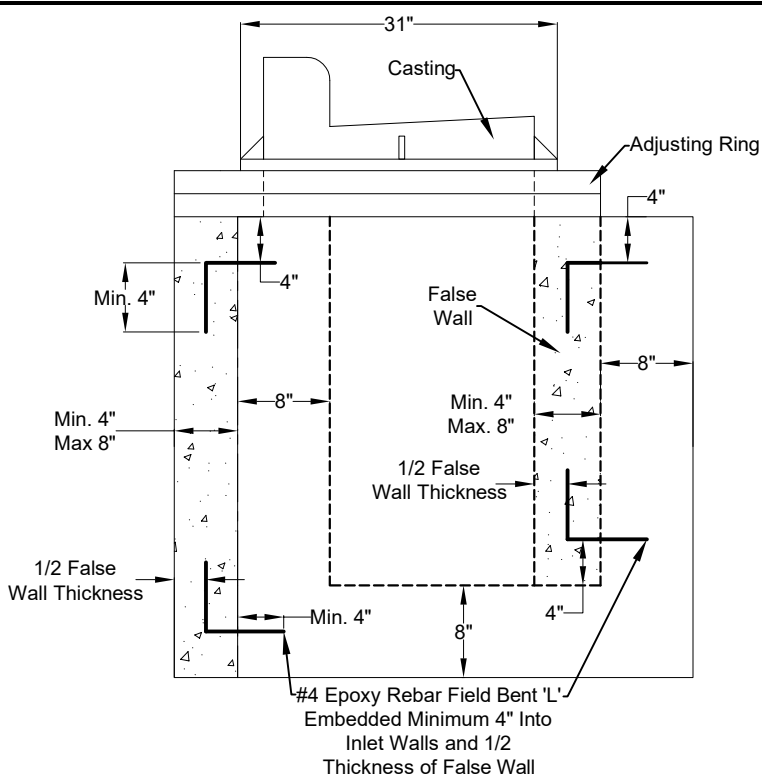

Note:

To insure the inlet casting is aligned correctly with the curb and gutter, an offset of the inlet casting may be required. The acceptable inlet casting offsets are shown and the guidelines are as follows:

- (1) If adjustment is required the inlet casting offset shall be obtained by the construction of two false walls with equal wall thickness varying from four to eight inches (4"-8") depending on the offset required. The placement and anchoring shall be constructed in the manner shown.
- (2) If the adjustment required is greater than eight inches (8"), the inlet shall be repositioned or reconstructed to reduce the offset.

***Offset Using False Wall
Inlet Side View***

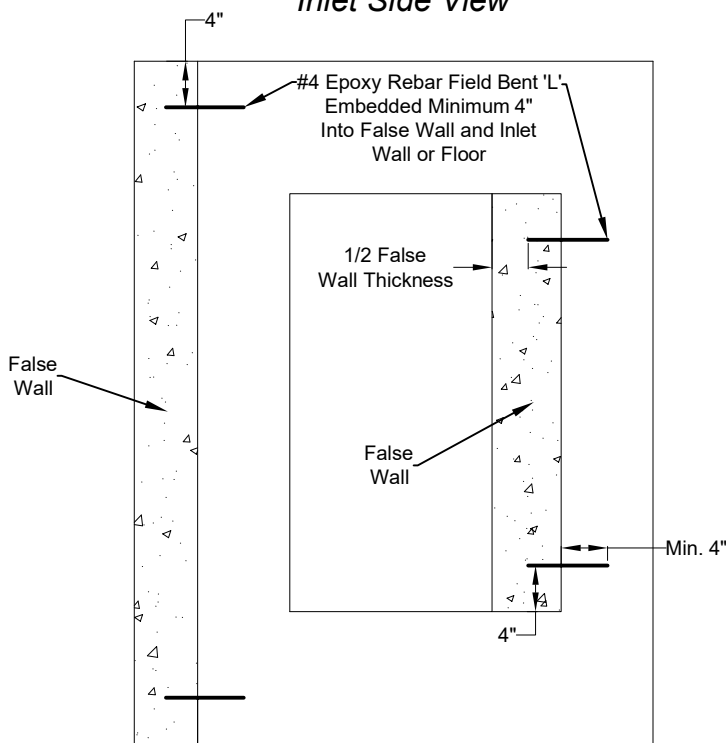

***Offset Using False Wall
Inlet Top View***

These specifications are applicable for both poured-in-place and precast inlets. The detail shows a poured-in-place inlet. A precast inlet would only differ with a wall thickness of 5".

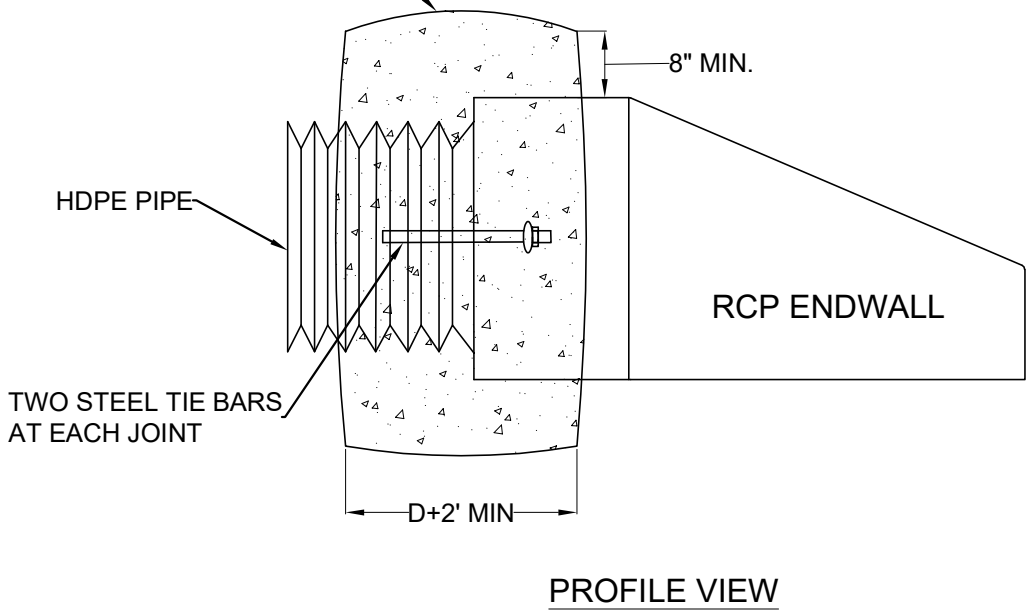
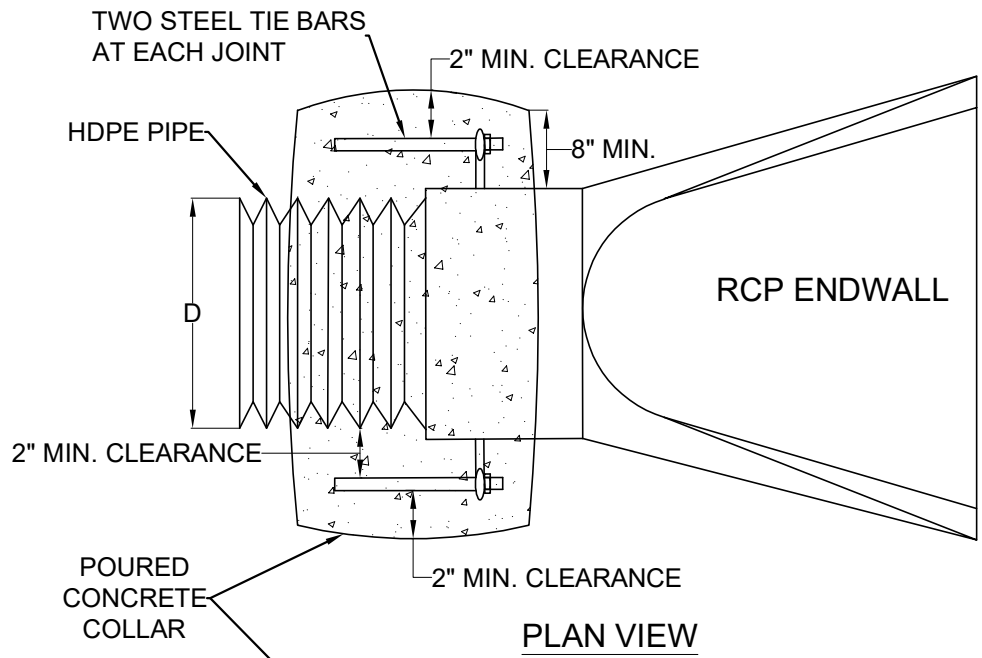

NOTE:

- 1) BOLT STEEL JOINT TIES TO ENDWALL, DO NOT ATTACH TO HDPE PIPE.

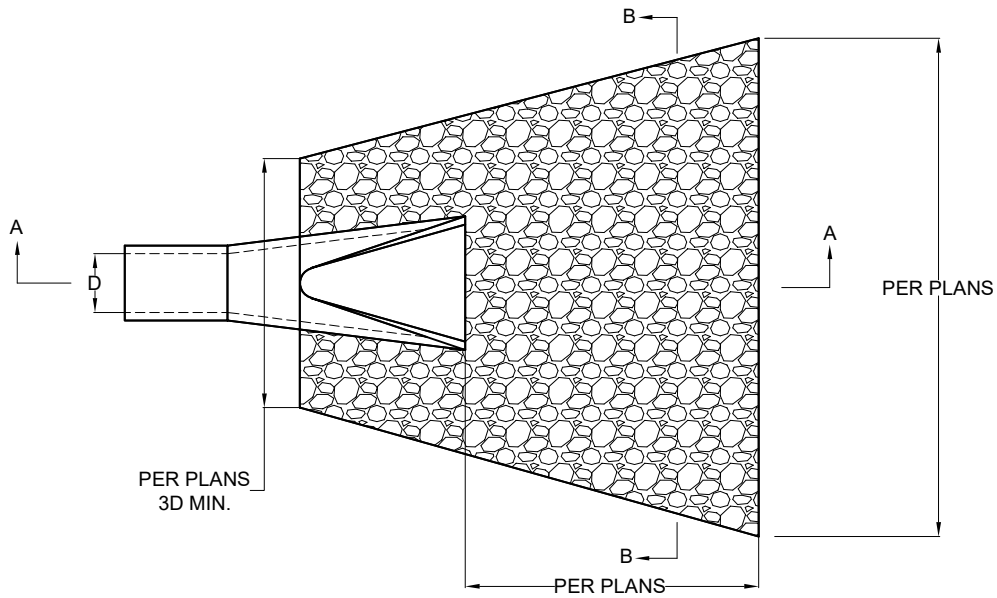

PLAN VIEW

NOTE: RIPRAP SHALL EXTEND TO TOE OF SLOPE MIN.

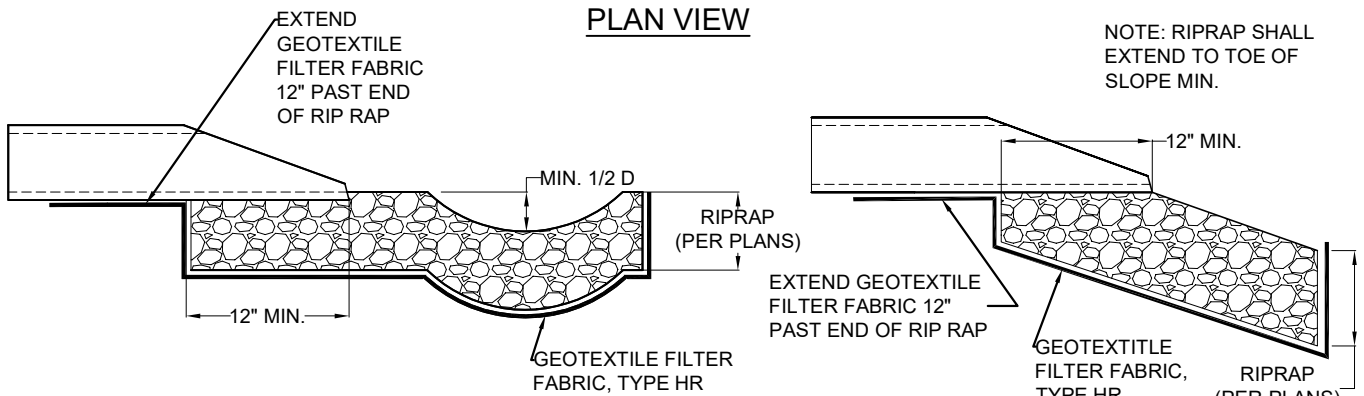

SLOPED/FLAT SWALE DISCHARGE AND FLAT POND DISCHARGE

SLOPED POND DISCHARGE

CROSS SECTION A-A

1) JOINT TIES SHALL BE INSTALLED AT THE LAST (DOWNSTREAM) TWO JOINTS ON ANY PIPE RUN ENDING IN AN APRON ENDWALL.

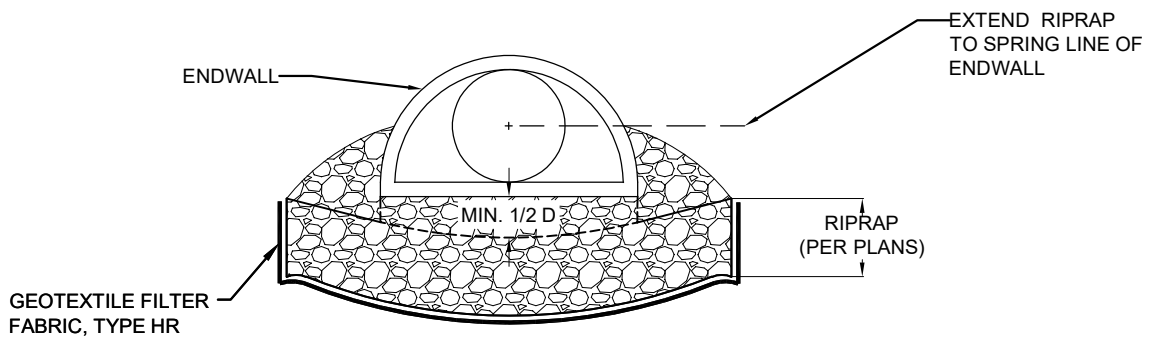



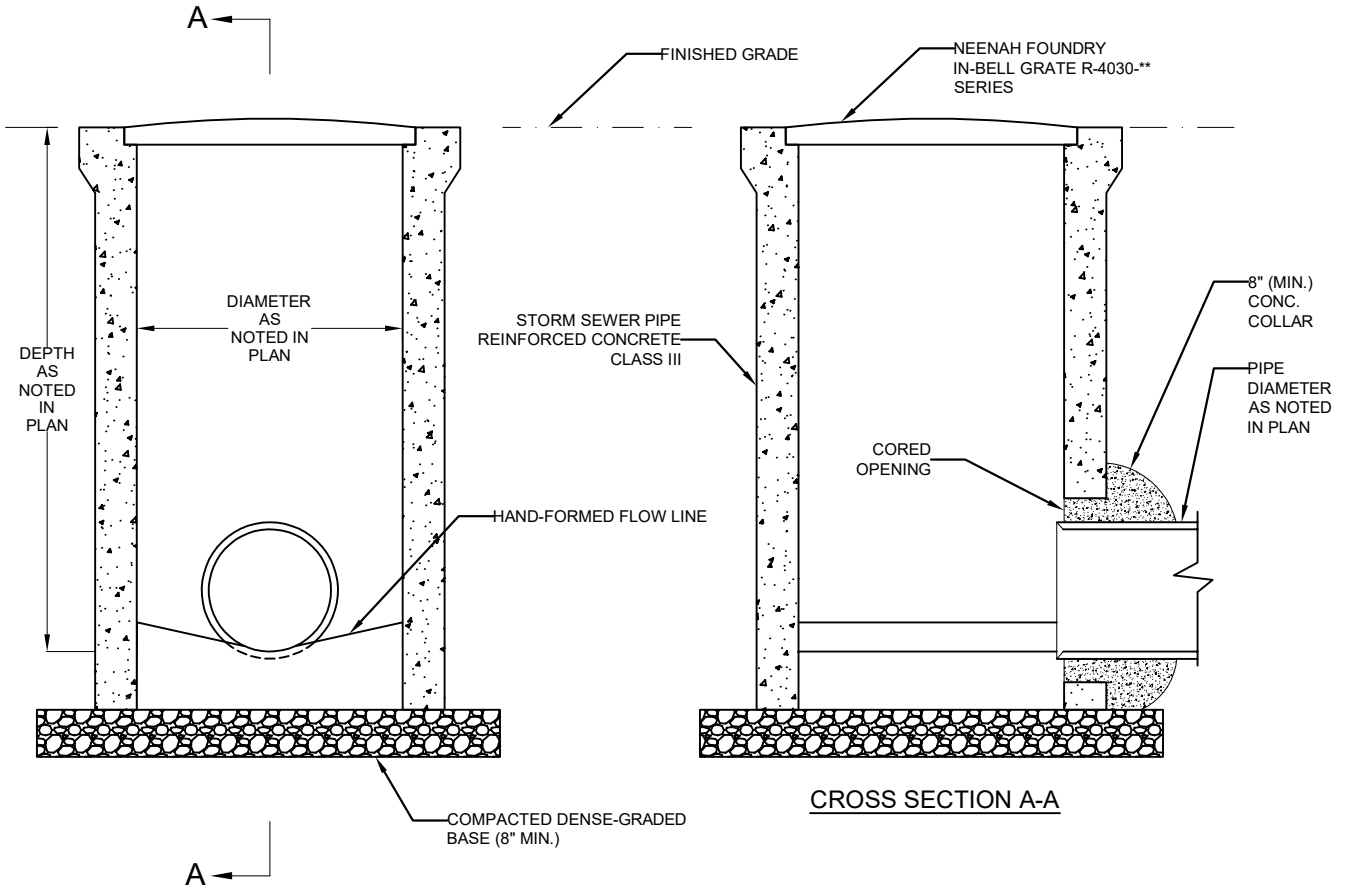

CROSS SECTION B-B

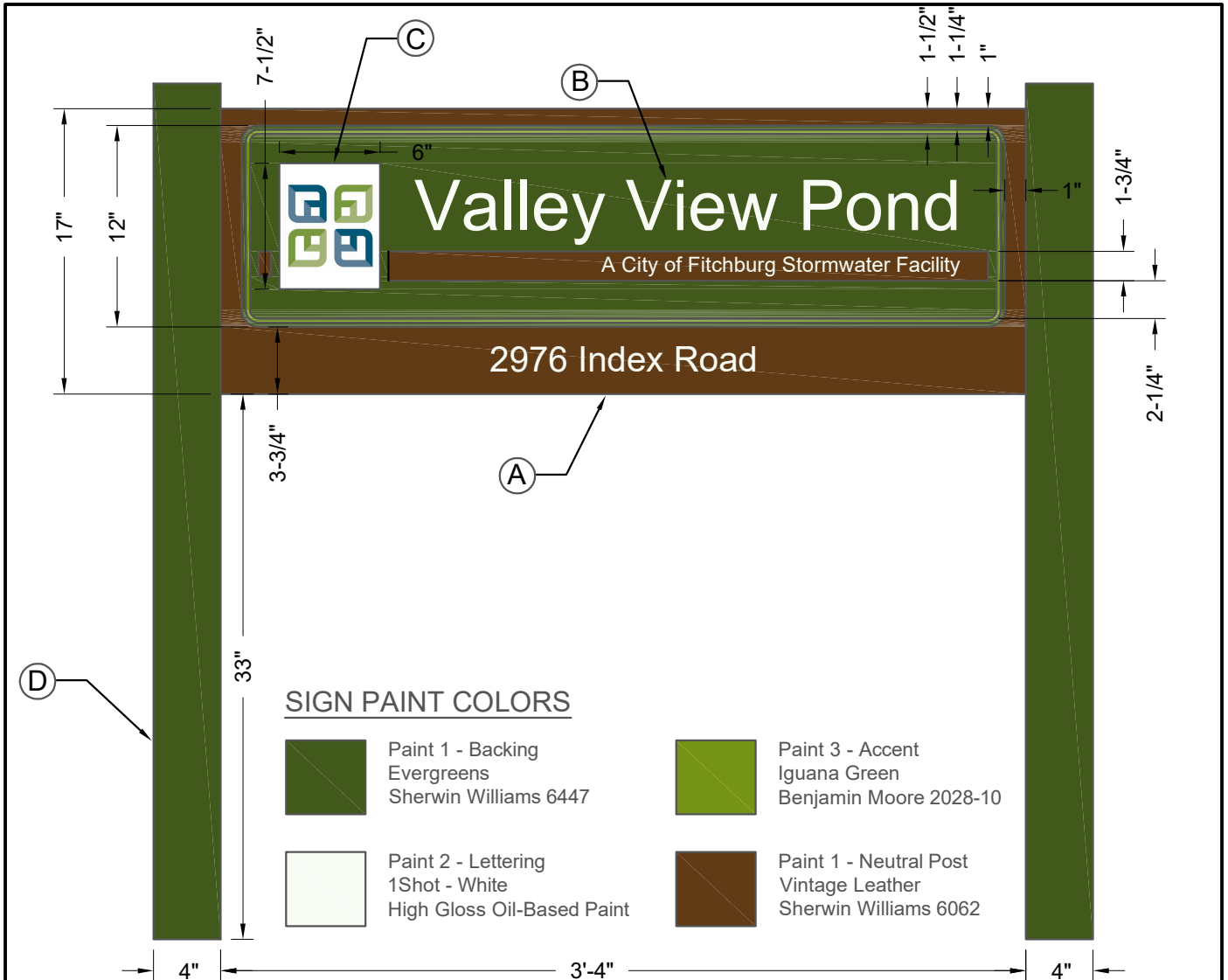

CROSS SECTION A-A



SIGN PAINT COLORS

- | | | | |
|---|--|---|--|
|  | Paint 1 - Backing
Evergreens
Sherwin Williams 6447 |  | Paint 3 - Accent
Iguana Green
Benjamin Moore 2028-10 |
|  | Paint 2 - Lettering
1Shot - White
High Gloss Oil-Based Paint |  | Paint 1 - Neutral Post
Vintage Leather
Sherwin Williams 6062 |



LOGO PAINT COLORS

	Leaf 1A Pantone #308c (100%) SW 6790 Adriatic Sea		Leaf 2A Pantone #377c (100%) SW 6719 Gecko
	Leaf 1B Pantone #308c (65%) SW 6789 Blue Mosque		Leaf 2B Pantone #377c (65%) SW 6717 Lime Rickey
			Background White

NOTES:

1. Pond name shall be approved by the City Engineer.
 2. Text shall be in the following sizes and fonts:
 Pond Name - 3.0 inches (Arial)
 Tag Line - 0.90 inches (Helvetica)
 Address - 1.5 inches (Helvetica)
- A) 1.5" Wood grain HDU - painted.
 B) 10yr 3M High performance vinyl letters.
 C) Painted wood logo.
 D) 4"x4" treated posts with stringers - painted.
- Signs from Vital Signs or approved equal.

SEE SIDE VIEW FOR
PLACEMENT OF RIPRAP
UNDER APRON ENDWALL

#6 DOWELS EMBEDDED 8"
INTO CUTOFF WALL. TOP
1" TO BE FILLED W/
CONCRETE EPOXY.

CONCRETE CUTOFF WALL DIM.
Z(W) x 3'(D) x 8"(W)

TOP VIEW

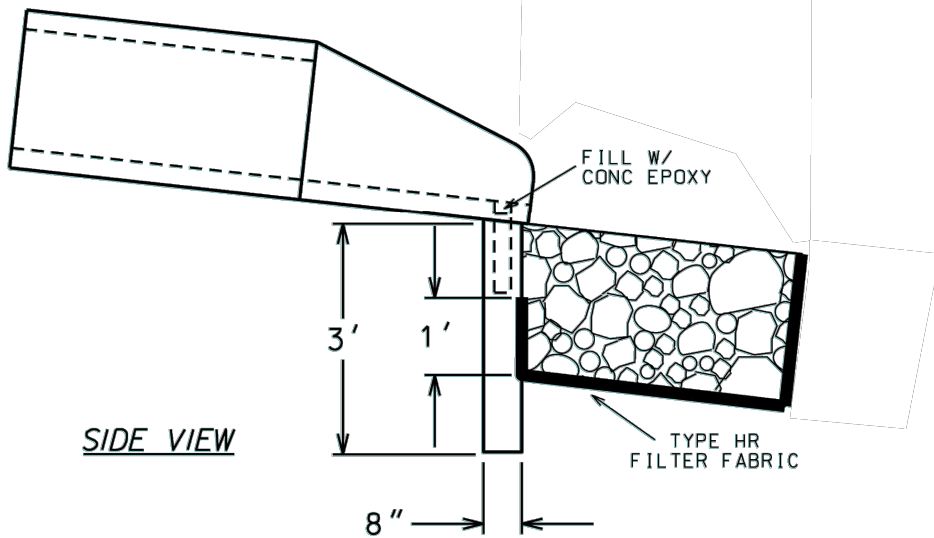

SIDE VIEW

DIA (in)	Z (in)
12	48
15	60
18	60
21	72
24	72
27	81
30	90
36	108
42	120
48	120
54	150
60	162
66	174
72	186

DETAIL COURTESY OF
CITY OF MADISON

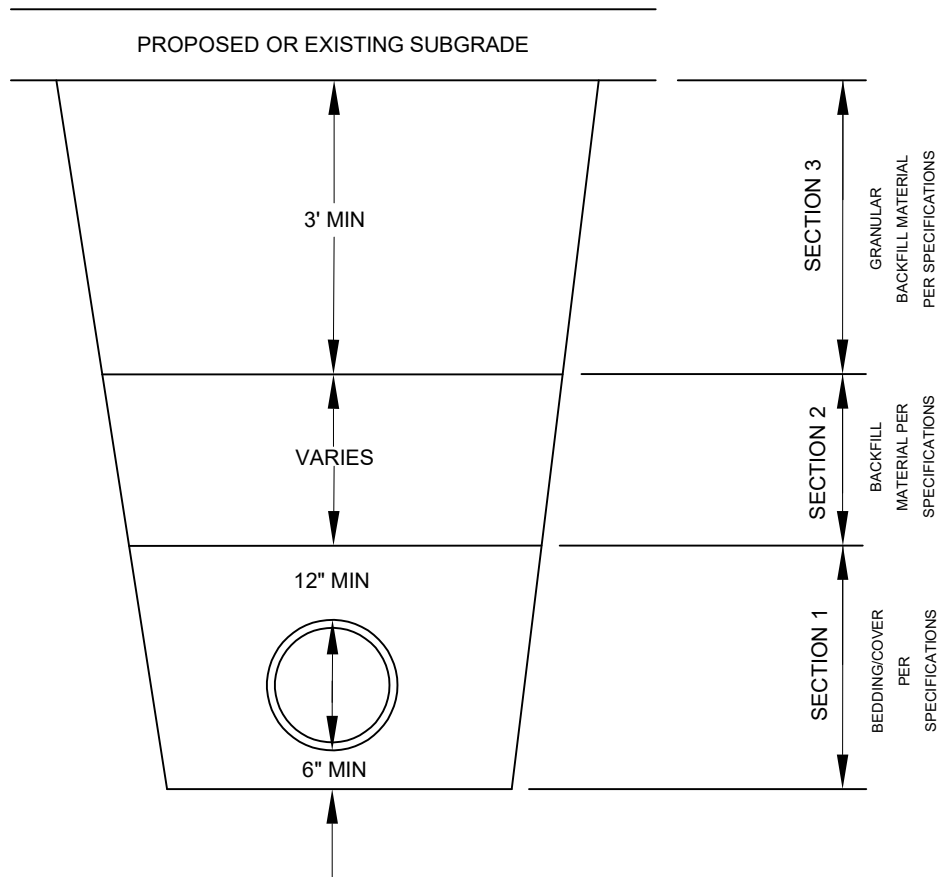

STANDARD TRENCH COMPACTION

ALL BACKFILL MATERIAL SHALL BE PLACED IN LIFTS NOT TO EXCEED 18" BEFORE COMPACTION UNLESS AUTHORIZED BY THE ENGINEER DUE TO THE CHARACTER OF THE MATERIAL AND THE COMPACTING EQUIPMENT. EACH LIFT SHALL BE MECHANICALLY COMPACTED TO THE REQUIRED DENSITY PRIOR TO PLACING SUCCEEDING LIFTS OF BACKFILL MATERIAL.

SECTION 1:

MECHANICALLY COMPACTED BEDDING AS REQUIRED BY THE SPECIFICATIONS. COMPACTION ACHIEVED WITH SMALLER PLATE COMPACTOR.

SECTION 2:

MINIMUM COMPACTION 90% MAXIMUM DENSITY. COMPACTION OF BACKFILL WITH BOMAG OR HOE-PAC SHALL NOT BEGIN UNTIL THE DEPTH OF BACKFILL MATERIAL IS TWO (2) FEET ABOVE THE TOP OF PIPE.

SECTION 3:

MINIMUM COMPACTION 95% MAXIMUM DENSITY.

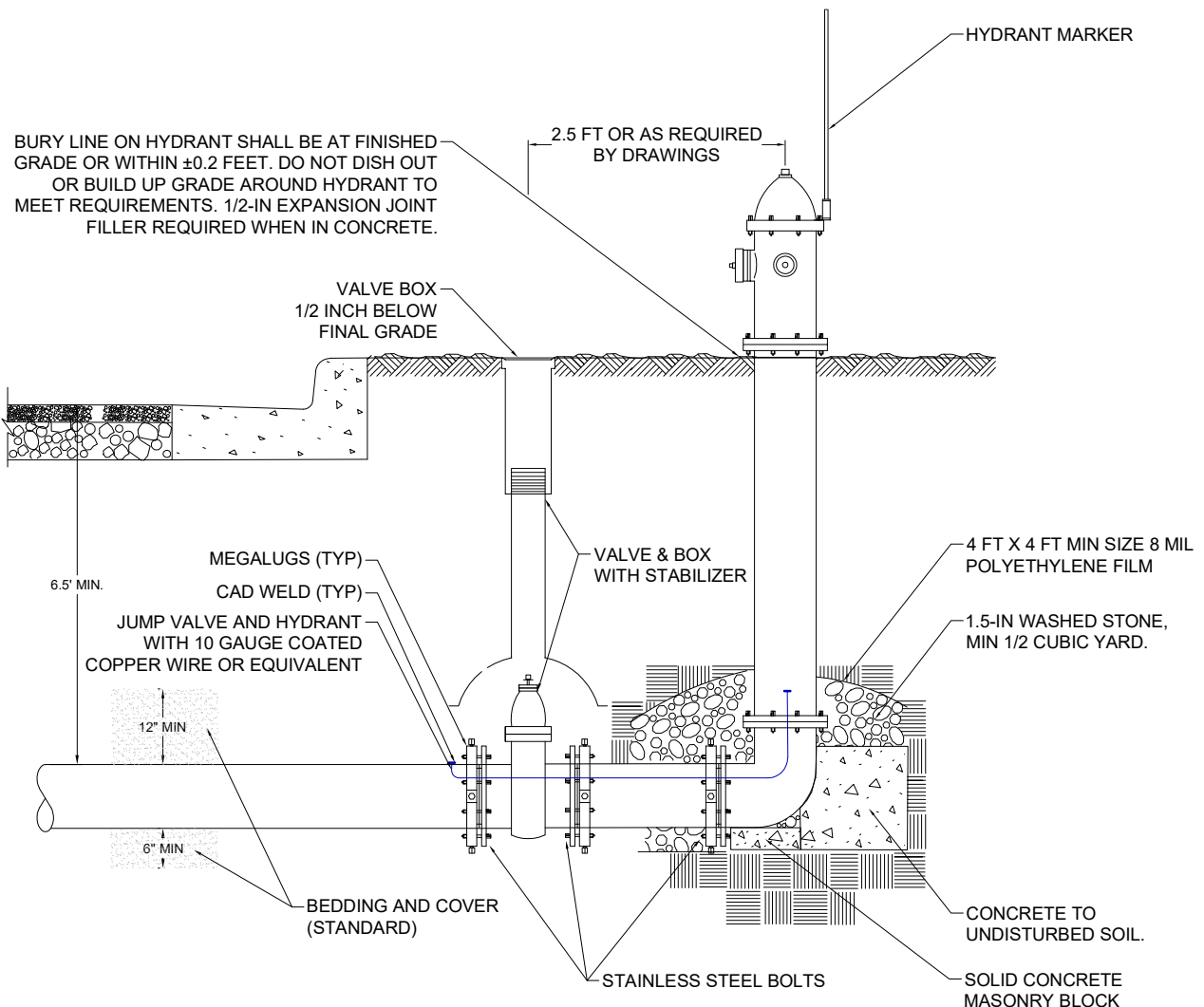

NOTE:

- 1) RESTRAIN ENTIRE LENGTH OF HYDRANT LEAD FROM THE TEE THROUGH THE VALVE TO THE HYDRANT
- 2) INSTALL 8 MIL POLYETHYLENE FILM ON HYDRANT LEAD PER MANUFACTURE'S REQUIREMENTS.

AWWA C600 Combined Pressure and Leakage Test for DI Water Main Pipe

L = $\frac{SD (150^{0.5})}{74000}$

- L = Testing allowance in gallons per 2 hours
- S = Length of pipe tested in feet
- D = Nominal diameter of pipe in inches
- P = Average test pressure during hydrostatic test in psi

Length	6" DI			8" DI			10" DI			12" DI		
	oz.	cups	gal.	oz.	cups	gal.	oz.	cups	gal.	oz.	cups	gal.
0	0	0.0	0.00	0	0.0	0.00	0	0.0	0.00	0	0.0	0.00
100	13	1.6	0.10	17	2.1	0.13	21	2.6	0.17	25	3.2	0.20
200	25	3.2	0.20	34	4.2	0.26	42	5.3	0.33	51	6.4	0.40
300	38	4.8	0.30	51	6.4	0.40	64	7.9	0.50	76	9.5	0.60
400	51	6.4	0.40	68	8.5	0.53	85	10.6	0.66	102	12.7	0.79
500	64	7.9	0.50	85	10.6	0.66	106	13.2	0.83	127	15.9	0.99
600	76	9.5	0.60	102	12.7	0.79	127	15.9	0.99	153	19.1	1.19
700	89	11.1	0.70	119	14.8	0.93	148	18.5	1.16	178	22.2	1.39
800	102	12.7	0.79	136	16.9	1.06	169	21.2	1.32	203	25.4	1.59
900	114	14.3	0.89	153	19.1	1.19	191	23.8	1.49	229	28.6	1.79
1000	127	15.9	0.99	169	21.2	1.32	212	26.5	1.66	254	31.8	1.99
1100	140	17.5	1.09	186	23.3	1.46	233	29.1	1.82	280	35.0	2.18
1200	153	19.1	1.19	203	25.4	1.59	254	31.8	1.99	305	38.1	2.38
1300	165	20.7	1.29	220	27.5	1.72	275	34.4	2.15	330	41.3	2.58
1400	178	22.2	1.39	237	29.7	1.85	297	37.1	2.32	356	44.5	2.78
1500	191	23.8	1.49	254	31.8	1.99	318	39.7	2.48	381	47.7	2.98
1600	203	25.4	1.59	271	33.9	2.12	339	42.4	2.65	407	50.8	3.18
1700	216	27.0	1.69	288	36.0	2.25	360	45.0	2.81	432	54.0	3.38
1800	229	28.6	1.79	305	38.1	2.38	381	47.7	2.98	458	57.2	3.57
1900	242	30.2	1.89	322	40.3	2.52	403	50.3	3.14	483	60.4	3.77
2000	254	31.8	1.99	339	42.4	2.65	424	53.0	3.31	508	63.6	3.97
2100	267	33.4	2.09	356	44.5	2.78	445	55.6	3.48	534	66.7	4.17
2200	280	35.0	2.18	373	46.6	2.91	466	58.3	3.64	559	69.9	4.37
2300	292	36.5	2.28	390	48.7	3.05	487	60.9	3.81	585	73.1	4.57
2400	305	38.1	2.38	407	50.8	3.18	508	63.6	3.97	610	76.3	4.77
2500	318	39.7	2.48	424	53.0	3.31	530	66.2	4.14	636	79.4	4.97
2600	330	41.3	2.58	441	55.1	3.44	551	68.9	4.30	661	82.6	5.16
2700	343	42.9	2.68	458	57.2	3.57	572	71.5	4.47	686	85.8	5.36
2800	356	44.5	2.78	475	59.3	3.71	593	74.1	4.63	712	89.0	5.56
2900	369	46.1	2.88	491	61.4	3.84	614	76.8	4.80	737	92.2	5.76
3000	381	47.7	2.98	508	63.6	3.97	636	79.4	4.97	763	95.3	5.96
3100	394	49.3	3.08	525	65.7	4.10	657	82.1	5.13	788	98.5	6.16
3200	407	50.8	3.18	542	67.8	4.24	678	84.7	5.30	813	101.7	6.36
3300	419	52.4	3.28	559	69.9	4.37	699	87.4	5.46	839	104.9	6.55
3400	432	54.0	3.38	576	72.0	4.50	720	90.0	5.63	864	108.0	6.75
3500	445	55.6	3.48	593	74.1	4.63	741	92.7	5.79	890	111.2	6.95
3600	458	57.2	3.57	610	76.3	4.77	763	95.3	5.96	915	114.4	7.15
3700	470	58.8	3.67	627	78.4	4.90	784	98.0	6.12	941	117.6	7.35
3800	483	60.4	3.77	644	80.5	5.03	805	100.6	6.29	966	120.8	7.55
3900	496	62.0	3.87	661	82.6	5.16	826	103.3	6.45	991	123.9	7.75
4000	508	63.6	3.97	678	84.7	5.30	847	105.9	6.62	1017	127.1	7.94
4100	521	65.1	4.07	695	86.9	5.43	869	108.6	6.79	1042	130.3	8.14
4200	534	66.7	4.17	712	89.0	5.56	890	111.2	6.95	1068	133.5	8.34
4300	547	68.3	4.27	729	91.1	5.69	911	113.9	7.12	1093	136.6	8.54
4400	559	69.9	4.37	746	93.2	5.83	932	116.5	7.28	1119	139.8	8.74
4500	572	71.5	4.47	763	95.3	5.96	953	119.2	7.45	1144	143.0	8.94
4600	585	73.1	4.57	780	97.4	6.09	974	121.8	7.61	1169	146.2	9.14
4700	597	74.7	4.67	797	99.6	6.22	996	124.5	7.78	1195	149.4	9.33
4800	610	76.3	4.77	813	101.7	6.36	1017	127.1	7.94	1220	152.5	9.53
4900	623	77.9	4.87	830	103.8	6.49	1038	129.8	8.11	1246	155.7	9.73
5000	636	79.4	4.97	847	105.9	6.62	1059	132.4	8.28	1271	158.9	9.93

File: I:\m-CH-FS01\CityHall\Public\Works\Templates\SPECIFICATIONS\Drawings\0204\2024\Details.dwg Layout: 703 User: Chelsea.Wilson Plotted: Jan 19, 2024 - 9:52am



WATER PRESSURE & LEAKAGE TEST
STANDARD DETAIL DRAWING

DATE: 1/9/2019
SHEET NO.: 7.03

Minimum Specified Time Required For a 1.0 Psig Pressure Drop For Size And Length Of Pipe Indicated												
Pipe Diameter, in	Minimum Time, min:s	Length for Minimum Time, ft	Time for Longer Length, s	Specification Time for Length (L) Shown, min:s								
				100 ft	150 ft	200 ft	250 ft	300 ft	350 ft	400 ft	450 ft	
4	3:46	597	0.380L	3:46	3:46	3:46	3:46	3:46	3:46	3:46	3:46	3:46
6	5:40	398	0.854L	5:40	5:40	5:40	5:40	5:40	5:40	5:40	5:40	6:24
8	7:34	298	1.520L	7:34	7:34	7:34	7:34	7:34	7:34	7:36	8:52	11:24
10	9:26	239	2.374L	9:26	9:26	9:26	9:53	9:53	11:52	11:52	13:51	17:48
12	11:20	199	3.418L	11:20	11:20	11:24	14:15	14:15	17:05	17:05	19:56	25:38
15	14:10	159	5.342L	14:10	14:10	17:48	22:15	22:15	26:42	26:42	31:09	40:04
18	17:00	133	7.694L	17:00	19:13	25:38	32:03	32:03	38:27	38:27	44:52	57:41
21	19:50	114	10.470L	19:50	26:10	34:54	43:37	43:37	52:21	52:21	61:00	78:31
24	22:40	99	13.674L	22:47	34:11	45:34	56:58	56:58	68:22	68:22	79:46	102:33
27	25:30	88	17.306L	28:51	43:16	57:41	72:07	72:07	86:32	86:32	100:57	129:48
30	28:20	80	21.366L	35:37	53:25	71:13	89:02	89:02	106:50	106:50	124:38	160:15
33	31:10	72	25.852L	43:05	64:38	86:10	107:43	107:43	129:16	129:16	150:43	193:53
36	34:00	66	30.768L	51:17	76:55	102:34	128:12	128:12	153:50	153:50	179:29	230:46



SANITARY PRESSURE TEST CHART
STANDARD DETAIL DRAWING

DATE: 1/9/2024
SHEET NO.: 8.01

Proper Tree Planting Diagram

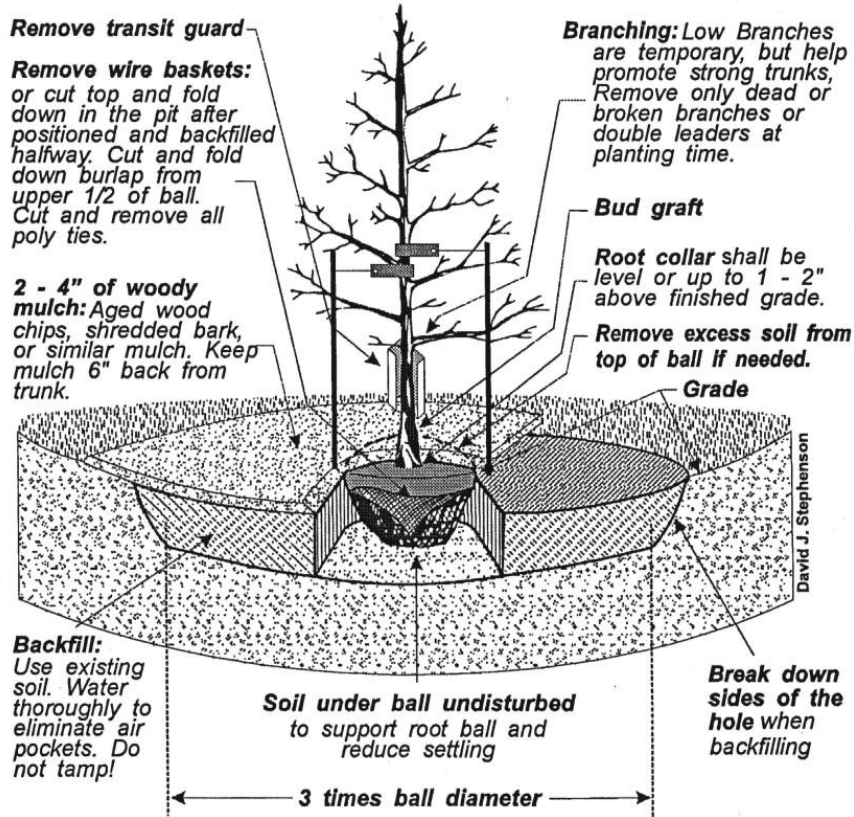

Stake only if you have to. Use 2-3"-wide webbing straps and secure to stakes with heavy gauge wire. The wire should be able to stick straight out from the stake and hold the webbing strap up, preventing it from sliding down the tree. Do not stake tightly - trees gain strength from movement. Remove all stakes after one year.

Use of tree wrap is not recommended, as it causes a number of problems for the tree.

Wisconsin Dept. Of Natural Resources - Oct. 2000

FULLY REMOVE TRANSIT GUARD,
NURSERY LABEL, PLANT LABELS,
TWINE & ROPES AFTER PLANTING

POSITION TREE SO THAT THE
LOWEST LIMBS ARE PARALLEL TO
THE CURB LINE

SINGLE, STRAIGHT, MAIN TRUNK.

TREE GRATED AS SPECIFIED FOR
PROJECT

REMOVE ROPES, STRINGS, WIRE
BASKETS, BURLAP AND ANY OTHER
WRAPPINGS FROM TOP $\frac{1}{3}$ OF BALL
AFTER PLANT HAS BEEN SET

WATER THOROUGHLY TO
ELIMINATE AIR POCKETS, AND TO
SETTLE THE SURROUNDING SOIL

PLANTING MIXTURE:
2 PARTS TOPSOIL: 1 PART SAND: 1
PART ORGANIC MATTER (PEAT
MOSS OR LEAF COMPOST)

FINISHED CONCRETE GRADE

MIN. 36" DEPTH
PLANTING
MIXTURE

4" CABC
DOT DENSE GRADED 3/4"

6" DEPTH PLANTING MIXTURE
BENEATH ROOT BALL
COMPACTED TO SUPPORT ROOT
BALL AND REDUCE SETTLING

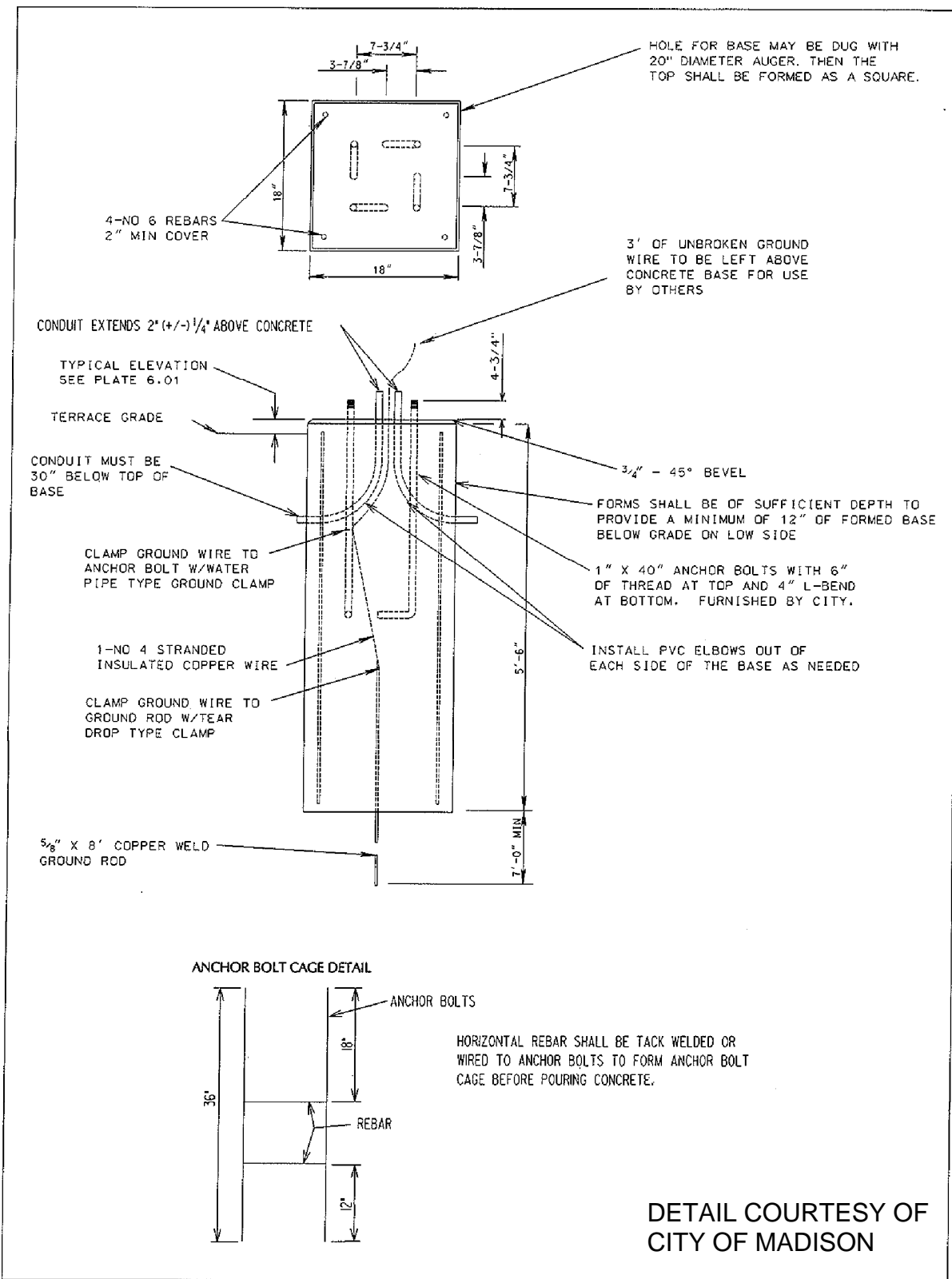
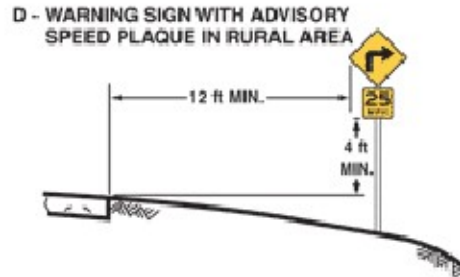
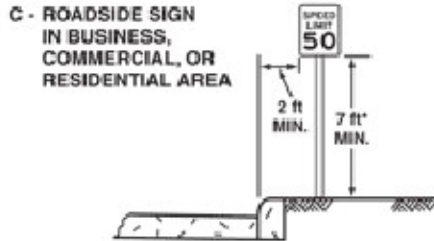
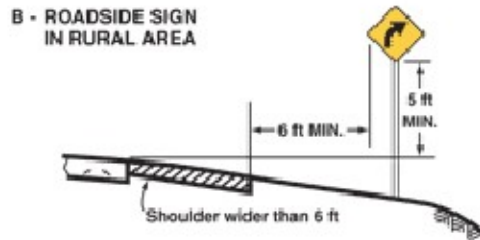
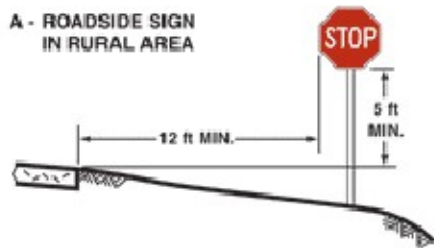
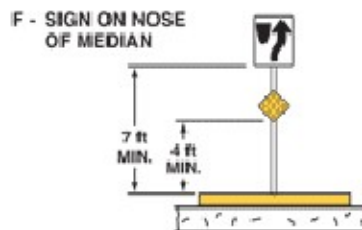
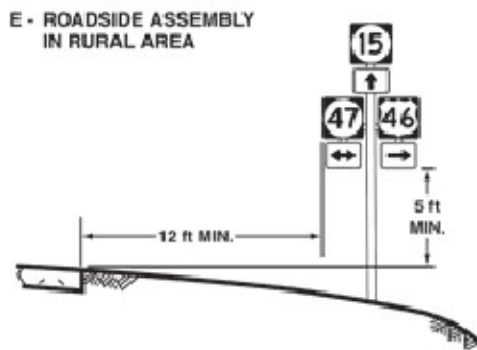

Figure 2A-2. Examples of Heights and Lateral Locations of Sign Installations



*Where parking or pedestrian movements are likely to occur



G - FREEWAY OR EXPRESSWAY SIGN WITH SECONDARY SIGN

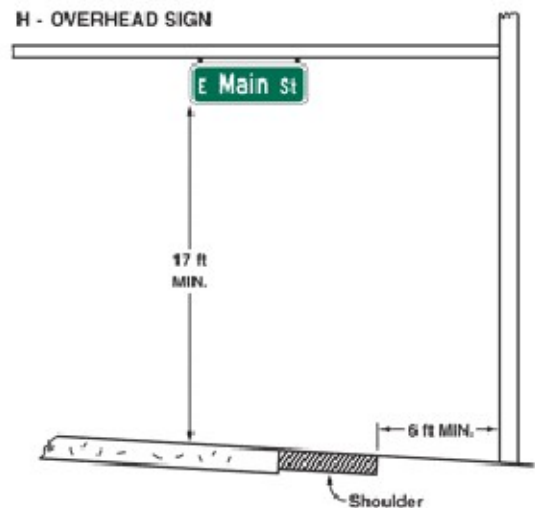
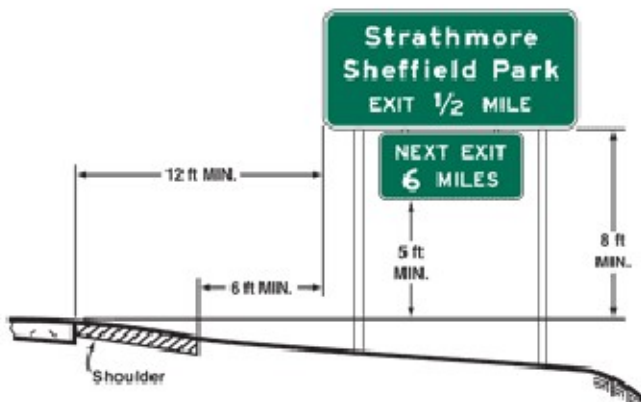

FOR MORE INFORMATION ACCESS FIGURE 2A-2 OF THE MUTCD
https://mutcd.fhwa.dot.gov/htm/2009/part2/fig2a_02_longdesc.htm

TYPE 1 CROSSWALK

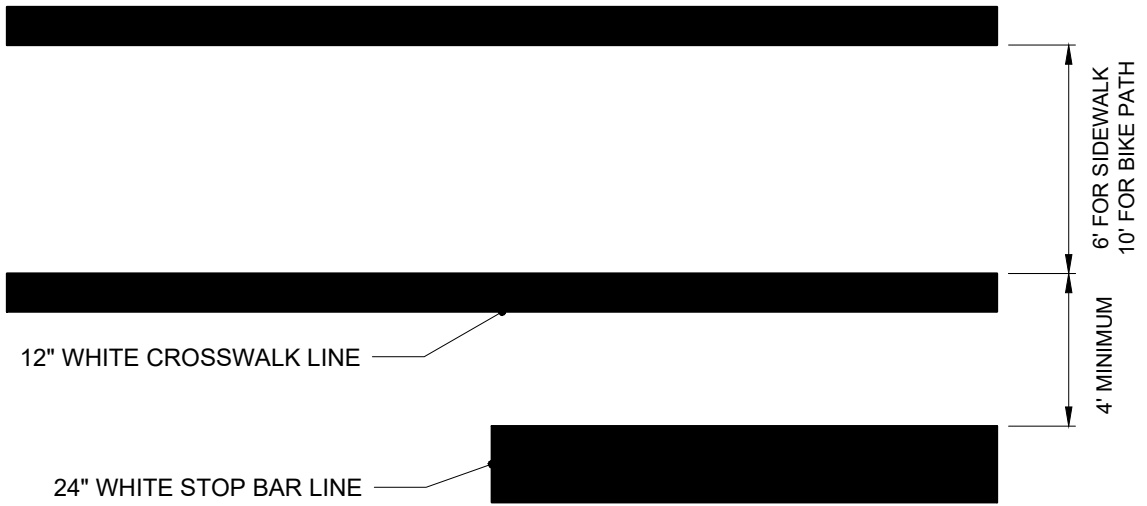

TYPE 2 CROSSWALK

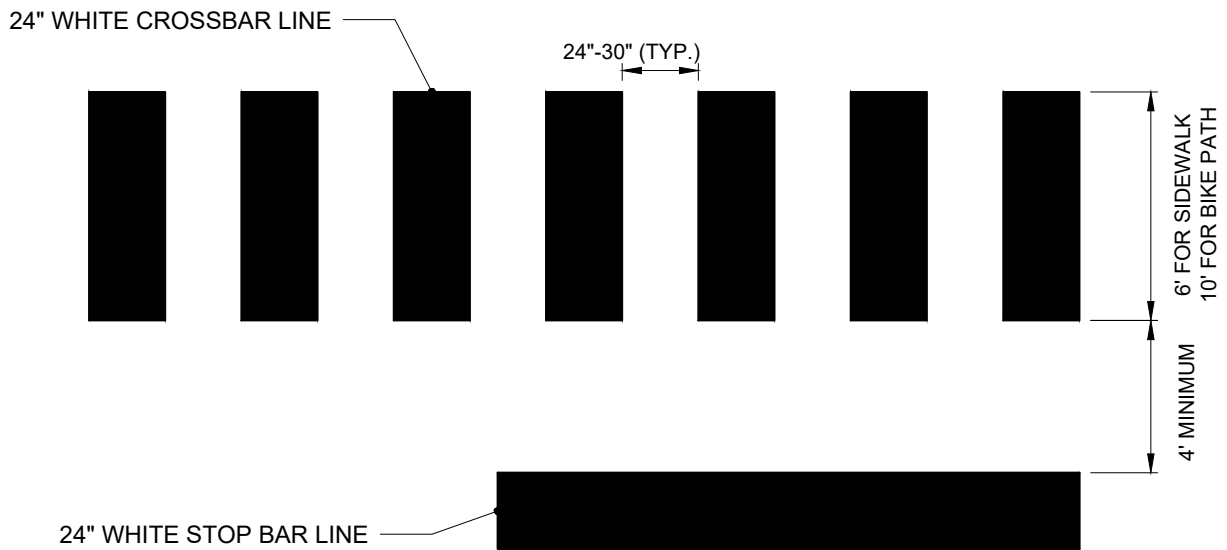

THE SPACING BETWEEN MARKED BARS VARIES FROM 24 TO 30 INCHES AND IS DETERMINED IN THE FIELD USING THE LANE-ROAD WIDTH. THE INTENT IS TO PLACE ONE 24 INCH CROSSBAR CENTERED ON THE CENTER LINE/LANE LINE WITH THE SECOND CROSSBAR CENTERED EQUALLY BETWEEN THE WHEEL TRACKS AND THE THIRD CROSSBAR PLACED AN EQUAL DISTANCE OUTSIDE THE WHEEL TRACK. IN NO CASE SHALL THE CROSSBAR BE PLACED IN OR NEXT TO THE GUTTER SECTION.